



V.V. Sangha's

# Rao Bahadur Y. Mahabaleswarappa Engineering College

(Formerly Vijayanagar Engineering College)

CANTONMENT, BALLARI - 583 104. (KARNATAKA)

(AFFILIATED TO VISVESWARAYA TECHNOLOGICAL UNIVERSITY, BELGAUM & APPROVED BY AICTE, NEW DELHI)

## CERTIFICATE

This is to certify that Mr. / Miss Mr. Ranjith

..... studying

in 7<sup>th</sup> Semester B.E. has

successfully completed by the experiments in Design

..... lab prescribed

by the Visveswaraya Technological University during the

academic year 2020 - 2021

Staff Incharge

40  
40

Head of the Department

Regd No. : 3V017ME014

Date : 16/01/2021

**INDEX**

Sl. No.	Date	Title of the Experiment	P. No.	Remarks
	11/12/20	LAB LAYOUT		
		Part-A		
1	12/12/20	1a. Simple pendulum	1-5	✓
		1b. Compound pendulum	6-7	✓
2	12/12/20	whirling of shaft	8-10	✓
3	26/12/20	Balancing of rotating masses	11-16	✓
4	26/12/20	Calibration of photo elastic material	17-21	✓
5	26/12/20	Determination of stress concentration factor (k)	22-25	✓
		Part - B		
6	18/12/20	watt and porter governor	26-28	✓

PART-ASIMPLE PENDULUM

- aim:
1. To investigate the fundamental physical properties of a simple pendulum.
  - To compare between experimental and theoretical period of oscillations.
  - To determine acceleration due to gravity using simple pendulum.

apparatus: Support stand, stop watch, pendulum bobs etc.

theory: A pendulum weight is suspended from pivot so that it can swing freely. When a pendulum is displaced from its resting equilibrium position, it is subjected to restoring force due to gravity. It will accelerate backward position.

procedure:

1. Attach the rubber bob to the cord and fix the cord to the <sup>main</sup> fixed point.
- For a fixed length, displace the bob from the equilibrium position to a small angle say  $10^\circ$

V V SANGHA'S RAO BAHADUR Y MAHABALESWARAPPA ENGINEERING COLLEGE DEPARTMENT OF MECHANICAL ENGINEERING Design Laboratory 2019-20 class 7 SEMESTER A-SECTION" Batch:A1 Laboratory Evaluation sheet													Total Marks
R. No.	USN	Name of the Student	Experiments										Max Mark
			1	2	3	4	5	6	7	8	9	10	40
A-1	3VC16ME007	ABHISHEK SINHA	4	3	4	3	4	4	4	4	4	4	38
A-2	3VC17ME001	AJAY REDDY N	4	4	4	4	4	4	4	4	3	4	39
A-3	3VC17ME002	AKASHA GOUDA H	4	3	4	4	3	4	3	4	4	4	37
A-4	3VC17ME003	ANIL KITTUR	4	4	4	4	4	4	4	4	4	4	40
A-5	3VC17ME004	BHARATHISHA A B	4	3	4	3	4	3	4	4	4	4	37
A-6	3VC17ME005	BHARGHAV R	3	4	3	4	4	4	4	4	4	4	38
A-7	3VC17ME006	C ESHWAR	4	3	4	4	4	4	4	4	3	3	37
A-8	3VC17ME007	DEEPAK PATIL S R	3	4	3	4	3	3	4	4	4	4	36
A-9	3VC17ME008	DODDA BASAVA B	4	4	3	4	4	4	3	3	4	4	37
A-10	3VC17ME009	DURJAYA K B	3	4	3	4	3	4	4	4	4	4	37
A-11	3VC17ME010	EARESH VARMA C	4	4	4	3	4	4	4	4	4	3	38
A-12	3VC17ME012	ERANAGOUDA K M	3	4	4	4	4	4	4	4	4	4	39
A-13	3VC17ME014	G RANJITH	3	4	4	4	4	4	4	4	4	3	38
A-14	3VC17ME016	G S SREE HARSHA	4	4	4	4	4	4	4	4	4	4	40
A-15	3VC17ME018	GANESH GOWDA M	4	4	3	3	4	4	4	4	3	3	36
A-16	3VC17ME019	GANESH J	4	3	3	4	4	4	4	4	4	4	38
A-17	3VC17ME020	GURUSIDDANA GOUDA B	4	4	4	4	4	4	4	4	4	4	40
A-18	3VC17ME021	HAMPANNA	3	4	4	4	4	4	4	4	4	4	39
A-19	3VC17ME022	HANUMESH	4	4	4	3	4	3	4	4	4	4	38
A-20	3VC17ME023	J M ABDUL KHADER BASHA	4	4	4	3	4	4	4	4	4	4	39
A-21	3VC17ME024	JAGADEESH	4	4	4	4	4	4	4	4	4	4	40

Lab Incharge  
(Dr. S. G. DESAI)  
SHIVA R

Staff  
Balya

Head of the Department,  
Mechanical Engineering Department,  
R.Y.M. Engineering Collage,  
Gantonment, BELLARY-583 104

R. No.	USN	Name of the Student	Experiments										Total Marks
A-22	3VC17ME025	JEFFREY SUJAN KUMAR K	4	3	4	4	4	4	4	4	4	4	39
A-23	3VC17ME027	K M PARIKSHITH	4	4	4	4	4	4	4	4	4	4	40
A-24	3VC17ME028	KAISARAHMED D	4	3	4	3	4	4	4	4	4	4	38
A-25	3VC17ME029	KARTHIK KUMAR D	4	3	4	4	4	4	4	4	4	4	39
A-26	3VC17ME030	KARTHIK R B	4	3	4	4	4	4	4	4	4	4	39
A-27	3VC17ME031	KIRAN MATH	4	3	4	4	4	3	4	4	4	4	38
A-28	3VC17ME032	LOKESHA NAIK	4	4	4	4	4	4	4	4	4	4	40
A-29	3VC17ME033	M CHAITANYA	4	3	4	4	4	4	4	4	4	4	39
A-30	3VC17ME041	MOHAMMED AZAM J	4	4	3	4	4	4	3	4	4	4	38
A-31	3VC17ME043	MOHAN E	4	4	4	4	4	4	4	4	4	4	40
A-32	3VC17ME046	NAVEEN SURAGOUNI	4	3	4	4	4	4	4	4	4	4	39
A-33	3VC17ME049	PAVAN KUMAR B	4	4	3	4	4	4	4	4	4	4	39
A-34	3VC17ME054	PAVITHRA R	4	3	4	4	4	4	4	4	4	4	39
A-35	3VC17ME081	VINAY KUMAR S	4	3	4	3	4	4	4	4	4	4	38
A-36	3VC17ME425	S MUSHTAQ AHMED	4	4	3	3	4	4	4	4	4	4	38
A-37	3VC18ME401	ANAND K R	4	3	4	3	4	4	4	4	4	4	38
A-38	3VC18ME402	ANIL KUMAR V	4	3	4	4	4	4	4	4	4	4	39
A-39	3VC18ME411	H M UDAY KUMAR	4	4	4	4	4	4	4	4	4	4	40
A-40	3VC18ME413	IMRAN ABDUL W B	4	4	4	4	4	4	4	4	4	4	40
A-41	3VC18ME415	K VINAY KUMAR	4	3	4	4	4	4	4	4	4	4	39
A-42	3VC18ME418	KIRAN KUMAR D	4	4	3	4	3	4	4	4	4	4	38
A-43	3VC18ME420	KUMAR K	4	3	3	3	4	4	4	4	4	4	37

Lab Incharge  
(Dr. S.G. Desai)  
Shivar

Staff  
K. Salga

  
Head of the Department,  
Mechanical Engineering Department,  
R.Y.M. Engineering Collage,  
Cantonment, BELLARY-583 104.



VEERASAIVA VIDYAVARDHAKA SANGHA'S, BALLARI  
RAO BAHADUR Y. MAHABALESWARAPPA ENGINEERING COLLEGE, BALLARI  
DEPARTMENT OF MECHANICAL ENGINEERING  
ACADEMIC YEAR :2020-21(EVEN SEMESTER)



## DEPARTMENT OF MECHANICAL ENGINEERING

A LAB MANUAL ON  
DESIGN LABORATORY

**2021-2022**

**Subject Code: 18MEL77**

**(For VII-sem Mech)**

**Lab in charge**  
**Dr. S G DESAI**

  
**Head of the Department**  
**Dr. KORI NAGRAJ**

**BALARAJ V**

**Name** \_\_\_\_\_

**Section/Branch** \_\_\_\_\_

**Semester** \_\_\_\_\_

**USN** \_\_\_\_\_

## LIST OF CONTENTS

SI No	Experiment Name	Page No
<b>PART-A</b>		
01	1a.Simple pendulum	1-4
	1b.Compound pendulum	5-6
02	Balancing of rotating masses	7-14
03	Whirling of shaft	15-19
04	<b>Centrifugal governor</b>	20-29
	Watt and Porter Governor	
	Proell Governor	
	Hartnell Governor	
<b>PART-B</b>		
05	<b>Determination of Fringe constant of Photo-elastic material using</b>	30-38
	a. Circular disc subjected to diametral compression.	New(30-33), Old(34-35)
	b. Pure bending specimen (Calibration of four point bending specimen)	36-38
06	Determination of stress concentration using Photo-elasticity for simple components like plate with a hole under tension or bending, circular disk with circular hole under compression.	39-41
07	Determination of Pressure distribution in Journal bearing	42-46
08	Determination of Principal Stresses and strains in a member subjected to combined loading using Rosette strain gauge	47-50
09	Determination of stresses in Curved beam using strain gauge.	
Viva Questions		51-53

## LIST OF FIGURES

Fig No	Figure Name	Page No
1	Simple Pendulum and its oscillations	2
2	Compound pendulum	5
3	Experimental setup of Balancing of rotating masses	new10,old 13
4	Schematic Layout of whirling of shaft apparatus	17
5	Schematic Representation of Porter Governor (without weight Watt), Proell Governors and Hartnel Governor	22(Fig 9)
6	Schematic Layout of Diffused light research polariscope(digital)	31(Fig6)
	Circular disc with central hole subjected to diametral compression	34
7	Setup for pure four point bending.	36(Fig7)
8	Circular disc with central hole subjected to diametral compression	40 (Fig 8)
9	Details of Journal, Bearing and loading arrangement and geometry of the journal bearing.	44(Fig 10)
10	Expected Graphs of (a)Axial pressure distribution (b) Circumferential Pressure Distribution (c) Radial Pressure Distribution polar diagram speed.	46(Fig 11)
11	Schematic of Rosette strain gauge	48(Fig 12)



**DESIGN LABORATORY**  
**B.E, VII Semester, Mechanical Engineering**  
**[As per Choice Based Credit System (CBCS) scheme]**

Course Code	18MEL77	CIE Marks	40
Number of Lecture Hours/Week	03 ( 1 Hour Instruction+ 2 Hours Laboratory)	SEE Marks	60
RBT Levels	L1, L2, L3	Exam Hours	03
<b>Course Learning Objectives:</b>			
<ul style="list-style-type: none"> <li>• To understand the concepts of natural frequency, logarithmic decrement, damping and damping ratio.</li> <li>• To understand the techniques of balancing of rotating masses.</li> <li>• To verify the concept of the critical speed of a rotating shaft.</li> <li>• To illustrate the concept of stress concentration using Photo elasticity.</li> <li>• To appreciate the equilibrium speed, sensitiveness, power and effort of a Governor.</li> <li>• To illustrate the principles of pressure development in an oil film of a hydrodynamic journal bearing.</li> </ul>			
<b>PART A</b>			
<ol style="list-style-type: none"> <li>1. Determination of natural frequency, logarithmic decrement, damping ratio and damping Co-efficient in a single degree of freedom vibrating systems (longitudinal and torsional)</li> <li>2. Balancing of rotating masses.</li> <li>3. Determination of critical speed of rotating shaft.</li> <li>4. Determination of equilibrium speed, sensitiveness, power and effort of Porter/Proell /Hartnell Governor.</li> </ol>			
<b>PART B</b>			
<ol style="list-style-type: none"> <li>1. Determination of Fringe constant of Photo-elastic material using. <ol style="list-style-type: none"> <li>a) Circular disc subjected to diametral compression.</li> <li>b) Pure bending specimen (four-point bending).</li> </ol> </li> <li>2. Determination of stress concentration using Photo-elasticity for simple components like plate with a hole under tension or bending, circular disk with circular hole under compression, 2D Crane hook.</li> <li>3. Determination of Pressure distribution in Journal bearing</li> <li>4. Determination of Principal Stresses and strains in a member subjected to combined loading using Strain.</li> <li>5. Determination of stresses in Curved beam using strain gauge.</li> </ol>			
<b>Course Outcomes:</b>			
<p>CO1: Compute the natural frequency of the free and forced vibration of single degree freedom systems, critical speed of shafts.</p> <p>CO2: Carry out balancing of rotating masses.</p> <p>CO3: Analyse the governor characteristics.</p> <p>CO4: Determine stresses in disk, beams, plates and hook using photo elastic bench.</p> <p>CO5: Determination of Pressure distribution in Journal bearing</p> <p>CO6: Analyse the stress and strains using strain gauges in compression and bending test and stress distribution in curved beams.</p>			

**Conduct of Practical Examination:**

1. All laboratory experiments are to be included for practical examination.
2. Breakup of marks and the instructions printed on the cover page of answer script to be strictly adhered by the examiners.
3. Students can pick one experiment from the questions lot prepared by the examiners.

**REFERENCE BOOKS**

- [1] “Shigley’s Mechanical Engineering Design”, Richards G. Budynas and J. Keith Nisbett, McGraw-Hill Education, 10th Edition, 2015.
- [2] “Design of Machine Elements”, V.B. Bhandari, TMH publishing company Ltd. New Delhi, 2nd Edition 2007.
- [3] “Theory of Machines”, Sadhu Singh, Pearson Education, 2nd Edition, 2007.
- [4] “Mechanical Vibrations”, G.K. Grover, Nem Chand and Bros, 6th Edition, 1996.

**Scheme of Examination:**

One question from Part A: **40 Marks**

One question from part B: **40 Marks**

Viva- Voce : **20Marks**

**Total: 100 Marks**

**PART-A**

Exp No.01a:-

**SIMPLE PENDULUM**

Date: \_\_/\_\_/202

AIM:

1. To investigate the fundamental physical properties of a simple pendulum.
2. To compare between experimental and theoretical period of oscillations.
3. To determine acceleration due to gravity using simple pendulum.

APPARATUS: Support stand, stopwatch, pendulum bobs etc.THEORY:

A pendulum is a weight suspended from a pivot so that it can swing freely. When a pendulum is displaced from its resting equilibrium position, It is subject to a restoring force due to gravity that will accelerate it back toward the equilibrium position, When released, the restoring force combined with the pendulum's mass causes it to oscillate about the equilibrium position, swinging back and forth. The time for one complete cycle, a left swing and a right swing, Is called the period. A pendulum swings with a specific period which depends (mainly) on its length.

A simple pendulum may be described ideally as a point mass suspended by a mass less string from some point about which it is allowed to swing back and forth in a plane. A simple pendulum can be approximated by a small metal sphere which has a small radius and a large mass when compared relatively to the length and mass of the light string from which it is suspended. If a pendulum is set in motion so that it swings back and forth, its motion will be periodic. The time that it takes to make one complete oscillation is defined as the period  $T$ . Another useful quantity used to describe periodic motion is the frequency of oscillation. The frequency  $f$  of the oscillations is the number of oscillations that occur per unit time and is the inverse of the period,  $f = \frac{1}{T}$ . Similarly, The period is the inverse of the frequency,  $T = \frac{1}{f}$ . The maximum distance that the mass is displaced from its equilibrium position is defined as the amplitude of the oscillation. When a simple pendulum is displaced from its equilibrium position, There will be a restoring force that moves the pendulum back towards its equilibrium position, As the motion of the pendulum carries it past the equilibrium position, the restoring force changes its direction so that it is still directed towards the equilibrium position. If the restoring force  $F$  is opposite and directly proportional to the displacement  $x$  from the equilibrium position. So that it satisfies the relationship.

$F = - k x \dots\dots$  (Equation 1)

then the motion of the pendulum will be simple harmonic motion and its period can be calculated using the equation for the period of simple harmonic motion,

$T = 2 \times \pi \times \sqrt{\frac{K}{m}} \dots\dots\dots$  (Equation 2)

It can be shown that if the amplitude of the motion is kept small, Equation (2) will be satisfied and the motion of a simple pendulum will be simple harmonic motion, and Equation (2) can be used.

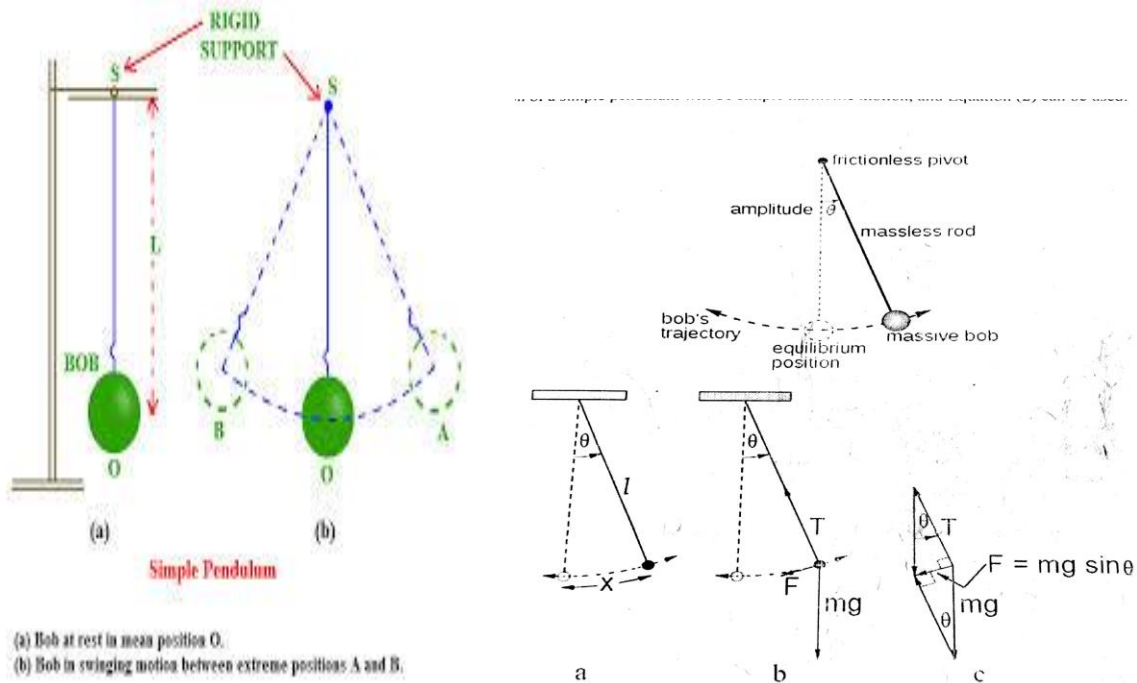

**Fig 1: Simple Pendulum and its oscillations**

The restoring force for a simple pendulum is supplied by the vector sum of the gravitational force on the mass, mg, and the tension in the string, T. The magnitude of the restoring force depends on the gravitational force and the displacement of the mass from the equilibrium position. Consider Figure where a mass m is suspended by a string of length l and is displaced from its equilibrium position by an angle theta and a distance x along the arc through which the mass moves. The gravitational force can be resolved into two components, one along the radial direction, away from the point of suspension, and one along the arc in the direction that the mass moves. The component of the gravitational force along the arc provides the restoring force F and is given by

$F = - mg \sin\theta \dots\dots\dots$  (Equation 3)

Where g is the acceleration of gravity, theta is the angle the pendulum is displaced. And the minus sign indicates that the force is opposite to the displacement. For small amplitudes

where  $\theta$  is small.  $\sin\theta$  can be approximated by  $\theta$  measured in radians so that equation (3) can be written as

$$F = - mg\theta \dots\dots\dots \text{(Equation 4)}$$

The angle  $\theta$  in radians is  $\frac{x}{l}$ , the arc length divided by the length of the pendulum or the radius of the circle in which the mass moves. The restoring force is then given by

$$F = - mg\frac{x}{l} \dots\dots\dots \text{(equation 5)}$$

And is directly proportional to the displacement  $x$  and is in the form of equation (1) where  $k = \frac{mg}{l}$ . Substituting this value of  $k$  into equation (2), the period of a simple pendulum can be found by

$$T = 2\pi \sqrt{\frac{m}{(\frac{mg}{l})}} \dots\dots\dots \text{(equation 6)}$$

And

$$T = 2\pi \sqrt{\frac{l}{g}} \dots\dots\dots \text{(Equation 7)}$$

**PROCEDURE:**

1. Attach the rubber bob to the cord and fix the cord to the main for fixed frame.
2. For a fixed length, displace the mass from the equilibrium position to a small angle say  $10^\circ$  (use this same fixed value throughout the experiment).
3. Start your timer as the bob passes through the equilibrium point ( Note; the start of the timer represents '0' cycle and & not one cycle).
4. Allow the bob to swing through 'n' complete oscillations (where 'n' is the range 10-30 depending on how fast the oscillations) and stop the timer at the end of the  $n^{\text{th}}$  cycle (oscillation).
5. Measure (with the timer) the time't' for these 'n' oscillation, then calculate the period,  

$$\tau = \frac{t}{n}.$$
6. Recode the data in table.
7. Change the length of the pendulum and repeat steps 2 to 4 until table is filled

**Observation:**

Weight of big ball(BOB) = 142 gms=0.142kg

Weight of small ball= 80Gms(BOB) = 0.08kg

TABULAR COLUMN 1 and 2: for **142Gms** (similarly draw for **80 Gms** also)

SL NO.	Length of the pendulum 'L' in cm	Time 't' for 'n' oscillations. in sec.	Period T in sec		T <sup>2</sup> exp in sec <sup>2</sup>	Angular frequency ω <sub>n</sub> ' in rad/sec		Acc due to gravity g <sub>exp</sub> m/sec <sup>2</sup>	Acc due to gravity g <sub>the</sub> m/sec <sup>2</sup>
			Theo	Expt		Theo	Expt		
1	20								
2	25								
3	30								
4	35								
5	40								

**CALCULATION:**

1. Period T

a) Period  $T_{exp} = \frac{t}{n}$  sec

b) Period  $T_{th} = \frac{2\pi}{\omega_n}$  sec

$\omega_{nth} = \sqrt{\frac{g}{L}}$  rad/sec where : T =Periodic time in Sec, L= length of Pendulum in cm

2. Angular frequency

3. Acc due to gravity : (exp)

a)  $\omega_{nth} = \frac{2\pi}{T_{th}}$

a)  $g_{exp} = \frac{4\pi^2 L}{T_{ex}^2}$

b)  $\omega_{exp} = \frac{2\pi}{T_{ex}}$

b)  $g_{th} = \frac{4\pi^2 L}{T_{th}^2}$

**GRAPH:** Case 1: For 80Gms of bob weight

Case 2: For 140 Gms of bob weight

a) Time period v/s Length

a) Time period v/s Length

b) T<sup>2</sup><sub>exp</sub> v/s Length

b) T<sup>2</sup><sub>exp</sub> v/s Length

**Result and Conclusion:** To investigate fundamentals of physical properties (Frequencies by varying length of the string and Weight of the Bob and the compare) and Compare T<sub>exp</sub> and T<sub>theo</sub> of simple pendulum and also determine Acceleration due to gravity.

Exp No.01b:-

**COMPOUND PENDULUM**

Date: \_\_/\_\_/202

AIM: To determine the radius of gyration (K) of given compound pendulum.

APPARATUS: Support stand, stopwatch, pendulum, compound, measuring tape, etc.

THEORY:

A rigid body that is free to swing under its own weight about a fixed axis of rotation is known as compound pendulum. The weight in a compound pendulum is not constructed as in ball, it is distributed in a solid bar depends on its mass, moment of inertia and center of gravity in addition to acceleration due to gravity.

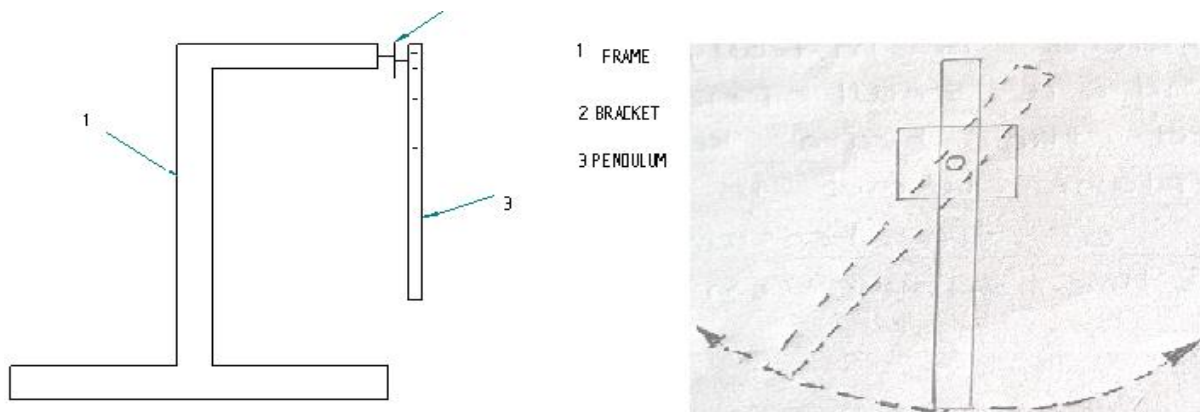

**Fig 2: Compound pendulum**

PROCEDURE:

1. Adjust the position of the weight and the support.
2. Find the distance of the center of gravity of the compound from oscillation point 'O' by placing pendulum on knife edge (OG).
3. Measure the period of oscillations T of the compound pendulum J and K
4. Repeat the step 1 to 3.

## Observation

Radius of gyration,  $k_{exp}$  in m       $T = 2\pi \sqrt{\frac{K^2 + OG^2}{g (OG)}}$

Where,

T= Periodic time in sec.

K= Radius of gyration about C G in cm=?

OG=Distance of the C G of rod from support

L= Length of suspended pendulum Cm

TABULAR COLUMN 3:

SL NO.	Length of the pendulum 'L' in Cm	Distance C G of rod from support(OG) In Cm	No of oscillations . 'n' in sec.	Time taken for 'n' oscillation 't' sec	Time period $T_{ex} = \frac{t}{n}$	Radiation of gyration $k_{exp}$ in m	
						Exp	Theo

CALCULATION:

1. Length of C.G from the support (OG) =  $\frac{L}{2} =$

2. Radius of gyration,  $k_{exp}$  in m

$$T = 2\pi \sqrt{\frac{K^2 + OG^2}{g(OG)}}$$

3. Radius of gyration,  $k_{th}$  in m

$$k_{th} = \frac{L}{2\sqrt{3}}$$

**Result and Conclusion:** The radius of gyration (K) of given compound pendulum is Determined;

Radius of gyration,  $k_{exp} =$

$$k_{th} =$$



AIM: To check experimentally the balancing of revolving masses rotating in different planes.

APPARATUS:

- i. Balancing of rotating mass apparatus
- ii. Measuring tape, Vernier Callipers
- iii. Weights, Studs, Lock nut.

THEORY:

1. INTRODUCTION

The balancing of rotating bodies is important to avoid vibrations. In heavy industrial machines such as steam turbines and electric generators. Vibration could cause catastrophic failure. Vibration is noisy and uncomfortable and when a car wheel is out of balance. The ride is quite unpleasant. In the case of a simple wheel. Balancing simply involves moving the centre of gravity to the centre of rotation but as we shall see. For longer and more complex bodies. There is more to it. For a body to be completely balanced it must have two things.

- a. **Static Balance:** This occurs when there is no resultant centrifugal force and the centre of gravity is on the axis of rotation.
- b. **Dynamic Balance:** This occurs when there is no resulting turning moment along the axis.

2. BALANCING IN ONE PLANE

If the system is a simple disc then static balance is all that is needed consider a thin disc or wheel on which the centre of gravity is not the same as the centre of rotation. A simple test for static balance is to place the wheel in frictionless bearings. The centre of gravity will always come to rest below the centre of rotation (like a pendulum). If it is balanced it will remain stationary no matter which position it is turned to.

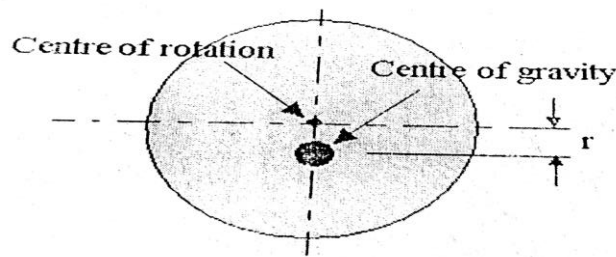

If the centre of gravity is distance  $r$  from the centre of rotation then when it spins at  $\omega$  rad/s. Centrifugal force is produced. This has a formula  $C.F = M\omega^2 r$  where  $M$  is the mass of the disc. This is the out of balance force. In order to cancel it out an equal and opposite force is needed. This is simply done by adding a mass  $M_2$  at a radius  $r_2$  as shown. The two forces must have the same magnitudes.

$$M\omega^2 r = M_2\omega^2 r_2$$

$$M r = M_2 r_2$$

Placing a suitable mass at a suitable radius moves the centre of gravity to the centre of rotation. This balance holds true at all speed to zero hence it is balanced so long as the products of  $M$  and  $r$  is equal and opposite.

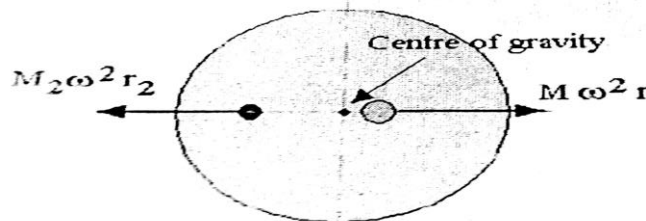

Figure 2

Now consider that our disc is out of balance because there are three masses attached to it as shown. The '3' masses are said to be coplanar and they rotate about a common centre.

The centrifugal force acting on each mass is  $F = M\omega^2 r$ . The radius of rotation is  $r$  and the angular velocity is  $\omega$  in rad/second. The force acting on each one is hence

$$F_1 = M_1\omega^2 r_1 \quad F_2 = M_2\omega^2 r_2 \quad F_3 = M_3\omega^2 r_3$$

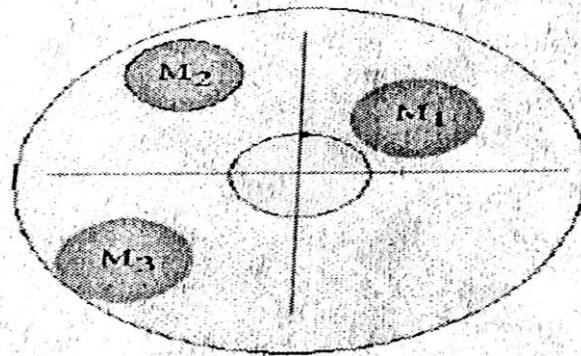

Figure 3

These are vector quantities and we can add them up to find the resultant force as shown.

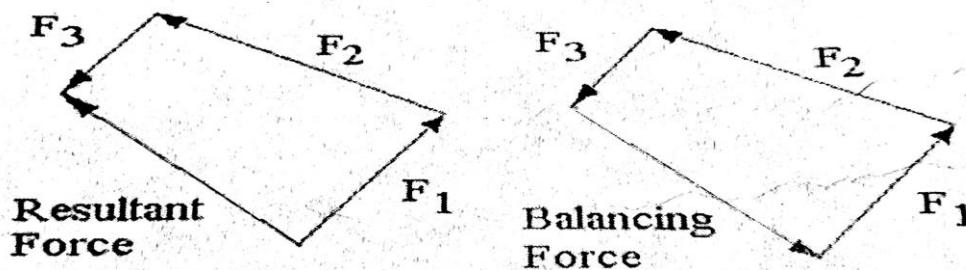

Figure 4

If the system was balanced, there would be no resultant force so the force needed to balance the system must be equal and opposite of the resultant (the vector that closes the polygon). The balancing mass  $M_4$  is then added at a suitable radius and angle such that the product  $M r$  is correct.

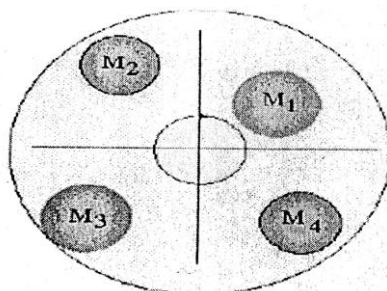

Figure 5

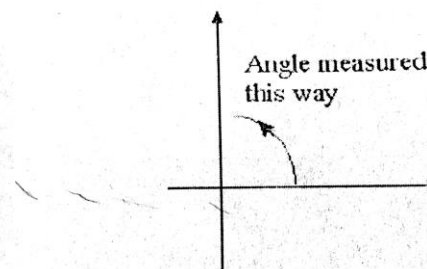
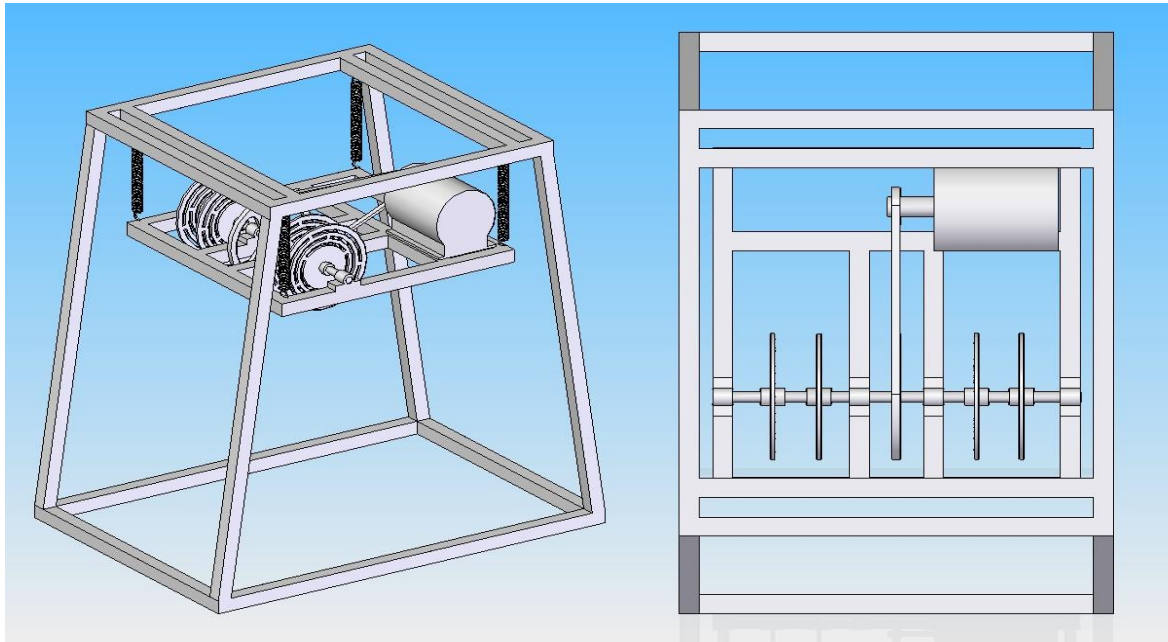

Figure 6

The result obtained would be the same whatever the value of  $\omega = 0$  we have static balance. In order to make the solution easier. We may make  $\omega = 1$  and calculate  $M r$  for each vector. This is called the  $M r$  polygon or vector diagram.

Note that angles will be given in normal mathematical terms with anticlockwise being positive from the x axis as shown.



**Fig 4: Experimental setup of Balancing of rotating masses.**

**PROCEDURE:**

1. Prepare the masses  $M_1$ ,  $M_2$ ,  $M_3$ ,  $M_B$  with the help of circular weights, bolts, nuts and washers. Ex  $M_1 = \text{Weight} + \text{Bolt mass} + \text{Washer mass} + \text{Nut mass}$
2. Run the machine without attaching the masses and note down the vibrations of the inner frame. This is called initial vibrations.
3. Stop the machine and now attach the masses  $M_1$ ,  $M_2$ ,  $M_3$  at radii  $r_1$ ,  $r_2$ ,  $r_3$  at angular positions  $\theta_1, \theta_2, \theta_3$  respectively choosing any single disc.
4. Run the machine notice that vibrations are setup in the inner frame than before. Record the vibration.
5. Stop the machine; attach the balancing mass  $M_B$  at radius  $r_b$  and at  $\theta_b$  angular position.
6. Run the machine and notice that the vibrations are reduced
7. Thus the solution obtained for several masses rotating in single plane is justified experimentally.

**Note:**

- a) Prepare the masses accurately by attaching washers, weights, bolt and nuts.
- b) Angular positions must be measured always in CCW direction of positive x axis.
- c) All the discs must be graduated and  $0^\circ$  if all discs must in single line.

## OBSERVATION :

Table 2.1 Availability of Masses

Sl. No.	Items	Mass in Gms	Quantity Available
1.	Weights	50	04
2.	Weights	100	04
3.	Weights	150	04
4.	Weights	200	04
5.	Studs	50	13
6.	Nuts	14	30
7.	Washers	08	45

**Calculation of Experiment Trial.1**

Three masses  $m_1$ ,  $m_2$  &  $m_3$  are 100gms, 150gms & 200gms respectively. The corresponding radii of rotation are 9.1cm, 11.6cm & 14.1cm respectively and angle of masses are  $0^\circ$ ,  $45^\circ$  &  $120^\circ$ . Find the position and magnitude of the balance mass required, if its radius of rotation is 9.1, 11.6, 14.1cm and 11.6. Add 1 stud, 2 nuts, 2 washes weights as 50gms, 28gms & 16gms respectively to the initial masses  $M_1$ ,  $M_2$  &  $M_3$ .

**Solution: Masses Used**

Masses	Weights in Gms	Studs in Gms	Nuts in Gms	Washers in Gms	Total mass in Gms
$M_1$	100	50	28	16	194
$M_2$	150	50	28	16	244
$M_3$	200	50	28	16	294
$M_4$	$M_B=?$	50	28	16	$M_B=?$

**Tabular column for Force polygon:**

Masses	Weights in Gms	Radius of rotation in Cm	Centrifugal force $F_c = Mr$ in Gms-Cm	Angular positions indegress
$M_1$	100	9.1	1765.4	0
$M_2$	150	11.6	2830.4	45
$M_3$	200	14.1	4145.4	120
$M_4$	$M_B=?$	11.6	$11.6 M_B$	$\theta_B=?$

1. Graphical Method:

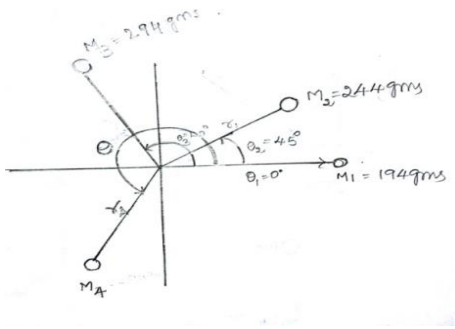

Fig: Space Diagram

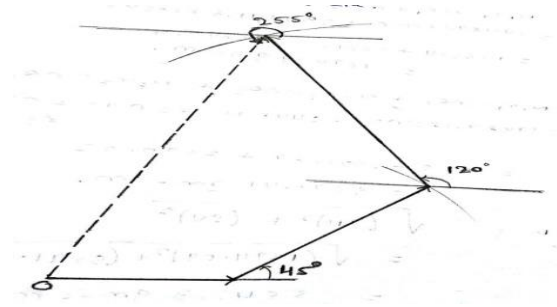

Fig: Force polygon

2. Check the Results by Analytical Method

Centrifugal force ( $\sum H=0$  and  $\sum V=0$  then system is statically balanced angular velocity ( $\omega$ )=1rad/sec )

$$\begin{aligned} \sum H &= FC_1 \cos\theta_1 + FC_2 \cos\theta_2 + FC_3 \cos\theta_3 \\ \sum H &= m_1 r_1 \omega^2 \cos\theta_1 + m_2 r_2 \omega^2 \cos\theta_2 + m_3 r_3 \omega^2 \cos\theta_3 \\ &= 194 \cdot 9.1 \cos 0 + 244 \cdot 11.6 \cos 45 + 594 \cdot 14.1 \cos 120 \\ &= 1765.4 + 2001.39 - 2072.7 \\ &= 1694.09 \text{ gm-cm} \end{aligned}$$

$$\begin{aligned} \sum V &= m_1 r_1 \sin \theta_1 + m_2 r_2 \sin\theta_2 + m_3 r_3 \sin\theta_3 \\ &= 194 \cdot 9.1 \sin 0 + 244 \cdot 11.6 \sin 45 + 594 \cdot 14.1 \sin 120 \\ &= 0 + 2000.39 + 3590.02 \\ &= 5591.41 \text{ gm-cm} \end{aligned}$$

$$\begin{aligned} R &= \sqrt{\sum H^2 + \sum V^2} \\ &= \sqrt{1694.09^2 + 5591.41^2} \Rightarrow R = 5842.3 \text{ gm-cm.} \end{aligned}$$

$$m_4 r_4 = 5842.3 \text{ m}_4 \Rightarrow 5842.3 / 11.6 \Rightarrow \mathbf{m_4 = 503.6 \text{ gm}} \Rightarrow 503.6 - 50 - 28 - 16 \Rightarrow \mathbf{m_4 = 409 \text{ gm}}$$

$$\tan \theta = \sum V / \sum H \Rightarrow 5591.41 / 1694.09 \Rightarrow 3.30 \Rightarrow \theta = \tan^{-1}(3.30), \theta_B \Rightarrow \mathbf{253.15^\circ}$$

GRAPHS:

For Static balancing

- Force polygon

**Result and Conclusion:** Thus the solution obtained for several masses rotating in single plane is justified experimentally (Statically balanced condition). (The arrangement of masses is as shown in the figure) .

## BALANCING OF ROTATING MASSES(OLD EXPERMENT)

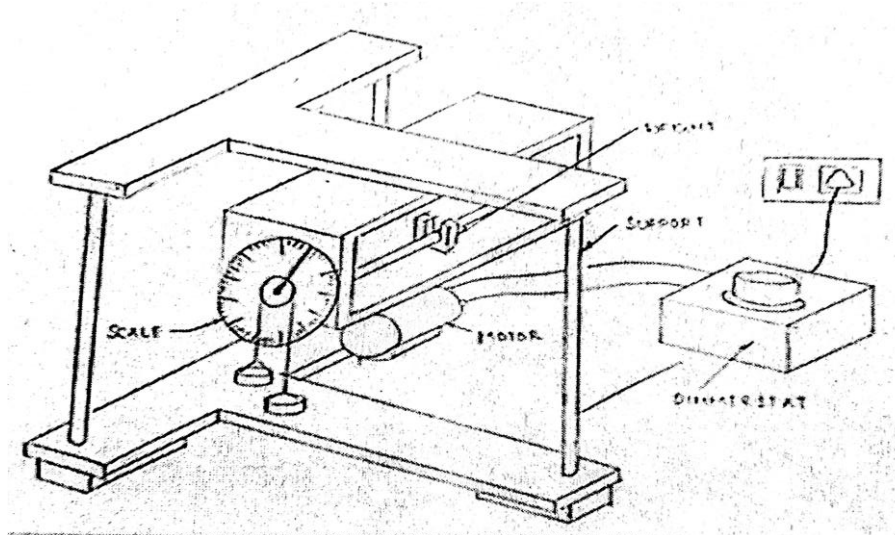

Fig:5 Balancing of rotating masses

PROCEDURE:

1. Clamp the main frame of the supporting frame by a nut and bolt
2. Clamp the isolating weight having mark as 1/a on the main shaft by the Allen key provided with the machine. Ensure that the weight is firmly clamped. It should move along with the shaft, while doing so care should be taken to indicate the pointer at infinity.
3. Attach the two weight pans by a light flexible string to the hook provided on the pulley. Let the string pass through the groves provided on the pulley
4. Now add the steel balls in any one of the weigh pans ensuring that both the weigh pans are in the horizontal level
5. Continue adding the steel balls until the rotating weight falls freely. Note that at this point the pointer shows  $90^{\circ}+10^{\circ}$ .
6. Count the total no of steel balls used for the above
7. Continue the process for all fine weight. Record the readings in the table
8. Select any 4 rotating weight at random Select any random distance between them and find the couple of all the forces with respect to any one of the forces
9. Now draw the couple polygon, force polygon and find out the angle of force

**OBSERVATION AND CALCULATION:**

Weight No	No of balls used	Mass of weight

**GRAPHS:**

- 2. Force polygon
- 3. Couple polygon

**RESULT:** The arrangement of masses is as shown in the figure



Exp No 03:-

**WHIRLING OF SHAFT**

Date \_\_\_ / \_\_\_ / 202

AIM: To determine the whirling speed of a given shaft and its critical frequency under whirling speed for different end conditions.

APPARATUS: Whirling of shaft apparatus, vernier caliper, measuring tape, shaft, and tachometer.

THEORY:

When a shaft rotates, it may well go into transverse oscillations. If the shaft is out of balance the resulting centrifugal force will induce the shaft to vibrate. When the shaft rotates at a speed equal to the natural frequency of transverse oscillations. This vibration becomes large and shows up as a whirling of the shaft. It also occurs at multiples of resonant speed. This can be very damaging to heavy rotating machines such as turbine generator sets and the system must be carefully balanced to reduce this effect and designed to have a natural frequency different to the speed of rotation. When starting or stopping such machinery. The critical speeds must be avoided to prevent damage to the bearings and turbine blades. Consider a weightless shaft supported by bearings and turbine blades. Consider a weightless shaft as shown with a mass  $M$  at the middle. Suppose the centre of the mass is not on the centre line.

When the shaft rotates, centrifugal force will cause it to bend out. Let the deflection of the shaft be  $r$  the distance to the centre of gravity is then  $r+e$ .

The shaft rotates at  $\omega$  rad/s. The transverse stiffness is  $K_t$  N/m

The deflection force is hence  $F = K_t r$

The centrifugal force is  $M\omega^2(r+e)$

Equating force we have

$$K_t r = M\omega^2(r+e) \text{ from which } r = \frac{M\omega^2(r+e)}{K_t} = \frac{M\omega^2 r}{K_t} + \frac{M\omega^2 e}{K_t}$$

$$r = \frac{M\omega^2 e}{K_t (1 - \frac{M\omega^2}{K_t})} \text{ It has already been shown that } \frac{K_t}{M} = \omega_n^2, r = \frac{\omega^2}{\omega_n^2 (1 - \frac{\omega^2}{\omega_n^2})} = \frac{e}{(\frac{\omega_n}{\omega})^2 - 1}$$

From this we see when  $\omega_n = \omega$ ,  $r = \frac{e}{0}$  which is infinity. This means that no matter how small the imbalance distance  $e$  is, the shaft will whirl at the natural frequency. Balancing does help but can never be perfect so whirling is to be avoided on the best of machines.

The frequencies at which whirling occurs are calculated by the same methods as for transverse vibrations of beams and the derivation is not given here.

**SIMPLY SUPPORTED :** - The ends are free to rotate normal to the axis ( e.g. self-aligning bearings)

$f = \frac{\pi}{2} n^2 \sqrt{\frac{EI}{wL^4}}$  where n is the mode and must be an integer 1.2.3.....

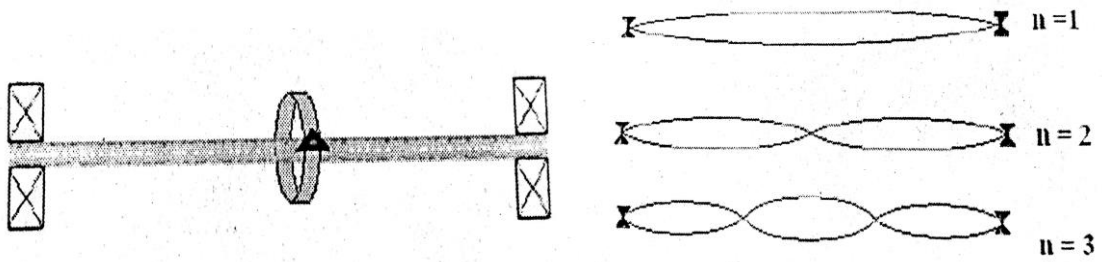

**FIXED ENDS** (e.g. fixed bearing or chucks)

The lowest critical speed is  $f = 3.562 \sqrt{\frac{EI}{wL^4}}$  and the higher critical speeds are given by

$f = \frac{\pi}{2} \sqrt{n + \frac{1}{2}} \sqrt{\frac{EI}{wL^4}}$  where n = 2.3..... Note that the lowest speed almost corresponds to n = 1

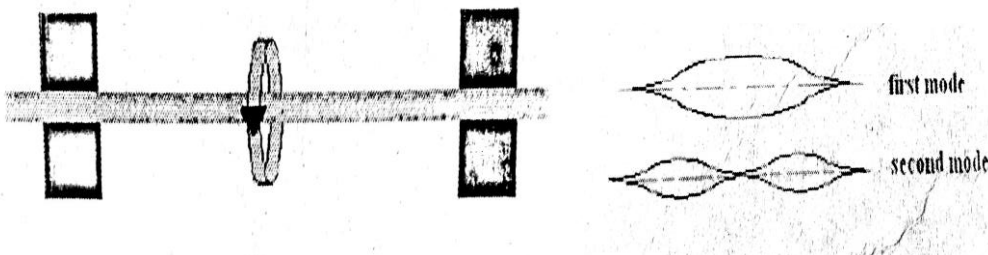

**CANTILEVER:**

The lowest critical speed is  $f = 0.565 \sqrt{\frac{EI}{wL^4}}$

$f = \frac{\pi}{2} \sqrt{n - \frac{1}{2}} \sqrt{\frac{EI}{wL^4}}$  where n = 2.3... Note that the lowest speed almost corresponds to n = 1

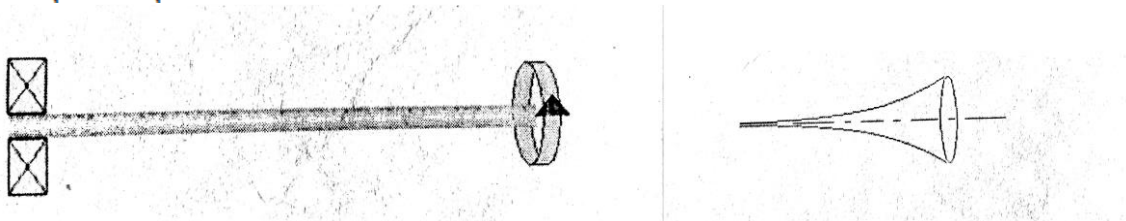



Experimental setup

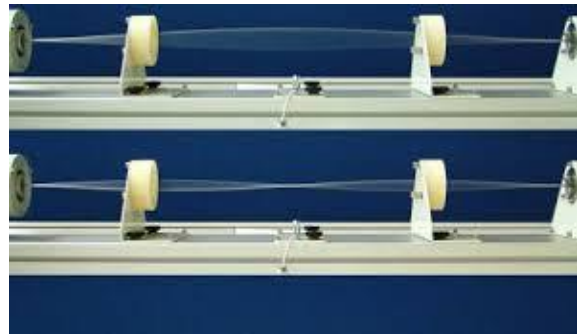

Whirling of shaft

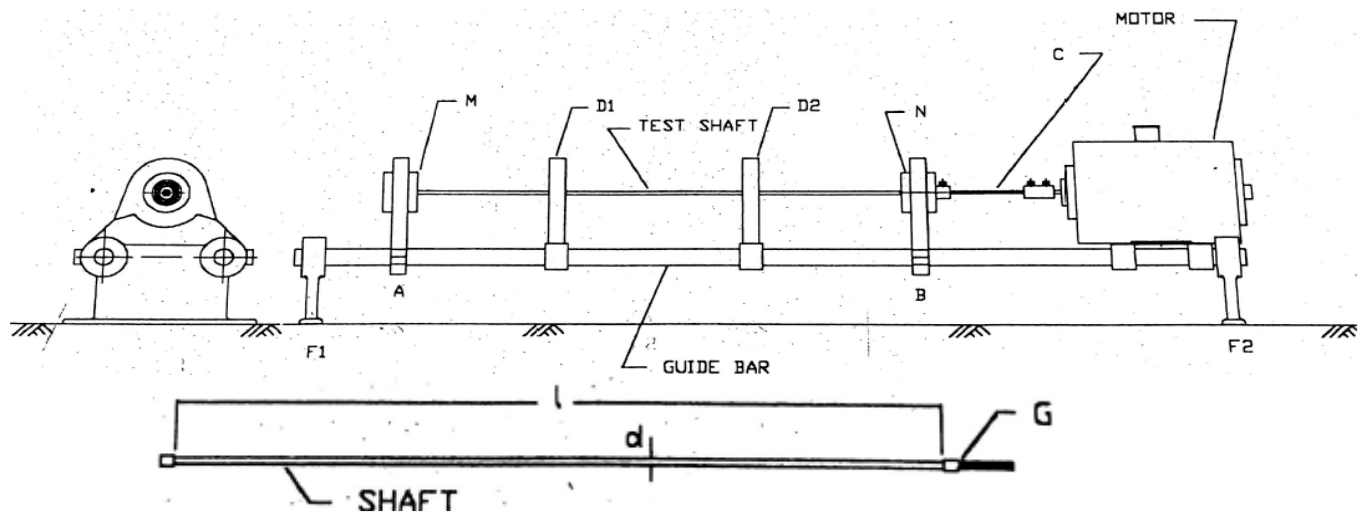

M-MM- Motor side free block , FM-Motor side fixed block, N-MT-Tail side free block, FT-Tail side fixed block, C- Flexible shaft, MN-Ball bearing Fixing ends, D1,D2-Guards, A,B-Stand for fixing M&N, F1,F2-Side supports, G-Bush at the shaft ends.

**Fig 3: Schematic Layout of whirling of shaft apparatus**

#### PROCEDURE:

1. Measure the diameter of the shaft using the vernier callipers( $d$ )
2. Measure the effective length of the shaft using a measuring tape ( $L$ )
3. Check the machine for all electrical connections
4. Start the motor and slowly increase the speed of the motor using a dimmer stat
5. At a certain speed, the shaft will start to vibrate violently and we get a single oval like shape. This is called as the "First mode"
6. Run the motor for some more time so that it will stabilize and note down the speed of the motor using a tachometer
7. Again by increasing the speed we get the second mode

OBSERVATION AND CALCULATIONS:

1. Diameter of the shaft,  $d = \text{----- mm} = \text{----- m}$
2. Length of the shaft,  $L = 90\text{cm} = 0.09\text{m}$  (measure) or  $92\text{Cm}$
3. Density of the shaft,  $\rho = 7970 \text{ kg/m}^3$
4. Mass/unit length of the shaft,  $m = \text{Area} \times \text{Density}$ ,  $m = \rho \left( \frac{\pi d^2}{4} \right)$  in  $\text{kg/m}$
5. Weight/unit length of the shaft,  $W = m \times g$ , in Newton.
6. Modulus of elasticity of the shaft,  $E = 200 \times 10^9 \text{ N/m}^2$
7. Acceleration due to gravity  $g = 9.81 \text{ m/sec}^2 = 9.81 \text{ m/s}^2$
8. Moment of inertia,  $I = \frac{\pi}{32} d^4$  in  $\text{m}^4$
9. Theoretical Critical frequency,  $F_{\text{Cth}} = k \sqrt{\frac{gEI}{WL^4}}$
10. Experimental,  $F_{\text{Cexp}} = \frac{Nc}{60}$

The various values of 'k' are given below, Constant of end condition  $K = 2.16$

Sl.No.	End Conditions	Values of 'k'		Fixed, Fixed Condition		
		Mode - I	Mode - II	Shaft diameter in Cm	Moment of Inertia(I) in $\text{Cm}^4$	Weight per unit length of Shaft (W) Kg/Cm
1	Supported, Supported	1.57	6.28	0.4	$25.39 \times 10^{-4}$	$0.15 \times 10^{-2}$
2	Fixed, Supported	2.45	9.80	0.6		
3	Fixed, Fixed	3.56	14.24	0.8		

<https://youtu.be/wIwdire8FYA> use this link for experimental procedure

**TABULAR COLUMN 5 (At least Three readings for each loop)**

SI No	Dia of the shaft 'd' in mm	End Condition	Whirling Speed 'N <sub>c</sub> ' in rpm(First loop mode)		Critical Natural Frequency in Hz		
					Theoretical	Experimental( $\frac{N_c}{60}$ )	
01	4	Fixed- Fixed	a			a	
			b			b	
			c			c	
02	6	Fixed-Fixed	a			a	
			b			b	
			c			c	
03	8	Fixed-fixed	a			a	
			b			b	
			c			c	

**Result and Conclusion:** To determined Whirling Speed of Given shaft for given end condition and its critical Frequency under whirling speed for given end condition (Conclusion).

AIM: To determine equilibrium speed, sensitiveness, power and effort of centrifugal

1 Watt governor and Porter governors

2 Proell governor

3. Hartnell governor

APPARATUS: Universal governor with weights, steel rule etc.

THEORY:

One of the simplest examples of a mechanical feedback control system is Governor. A Governor is a device used to control or maintain the speed within the prescribed limit for varying load conditions. As the load in the engine shaft increased, the speed of the shaft decreases and this is transmitted into the spindle by using a bevel gear. As the spindle speed increases and hence the ball moves towards which in turn increases the fuel supply to the engine thereby the speed is brought to a constant. When the load on the engine decreases the engine speed increases and also the spindle speed. Due to this increase in the speed the centrifugal force on the governor increases, which may make the fly balls move outward and the fuel supply to the engine is decreased thereby the speed is brought to a constant.

A centrifugal governor is a specific type of governor that controls the speed of an engine by regulating the amount of fuel (or working fluid) admitted, so as to maintain a near constant speed whatever the load or fuel supply conditions. It uses the principle of proportional control. It is most obviously seen on steam engines where it regulates the admission of steam into the cylinder(s). It is also found on internal combustion engines and variously fuelled turbines, and in some modern striking clocks. The device shown is from a steam engine. Power is supplied to the governor from the engine's output shaft by (in this instance) a belt or chain (not shown) connected to the lower belt wheel. The governor is connected to a throttle valve that regulates the flow of working fluid (steam) supplying the prime mover (prime mover not shown). As the speed of the prime mover increases, the central spindle of the governor rotates at a faster rate and the kinetic energy of the balls increases. This allows the two masses on lever arms to move outwards and upwards against gravity. If the motion goes far enough, this motion causes the lever arms to pull down on a thrust bearing, which moves a beam linkage, which reduces the

aperture of a throttle valve. The rate of working-fluid entering the cylinder is thus reduced and the speed of the prime mover is controlled, preventing over-speeding. Mechanical stops may be used to limit the range of throttle motion, as seen near the masses in the image at right. The direction of the lever arm holding the mass will be along the vector sum of the reactive centrifugal force vector and the gravitational force

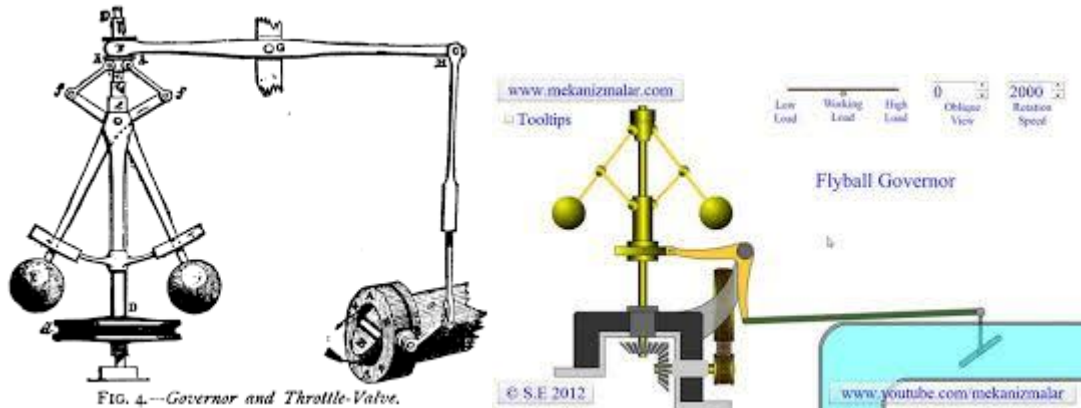

The Application of the governors

#### CLASSIFICATION OF THE GOVERNOR:

Governors are generally classified into

1. Centrifugal governors.
2. Inertia governors.
3. Spring loaded governors.
  1. A) Watt governor: Simple centrifugal governor with arms and links fitted with known masses without any centre load on the sleeve.
  - B) Porter governor: This is same as watt governor with extra centre load on the sleeve.
  - C) Proell governor: This is also centrifugal type of governor with masses attached at the end of an extended arm. In the proell governor, with the use of flyweights (forming full ball) the governor becomes highly sensitive. Under these conditions large sleeve displacement is observed for every small change in speed. In order to make it stable, it is necessary to carry out the experiments by using half ball flyweight on each side

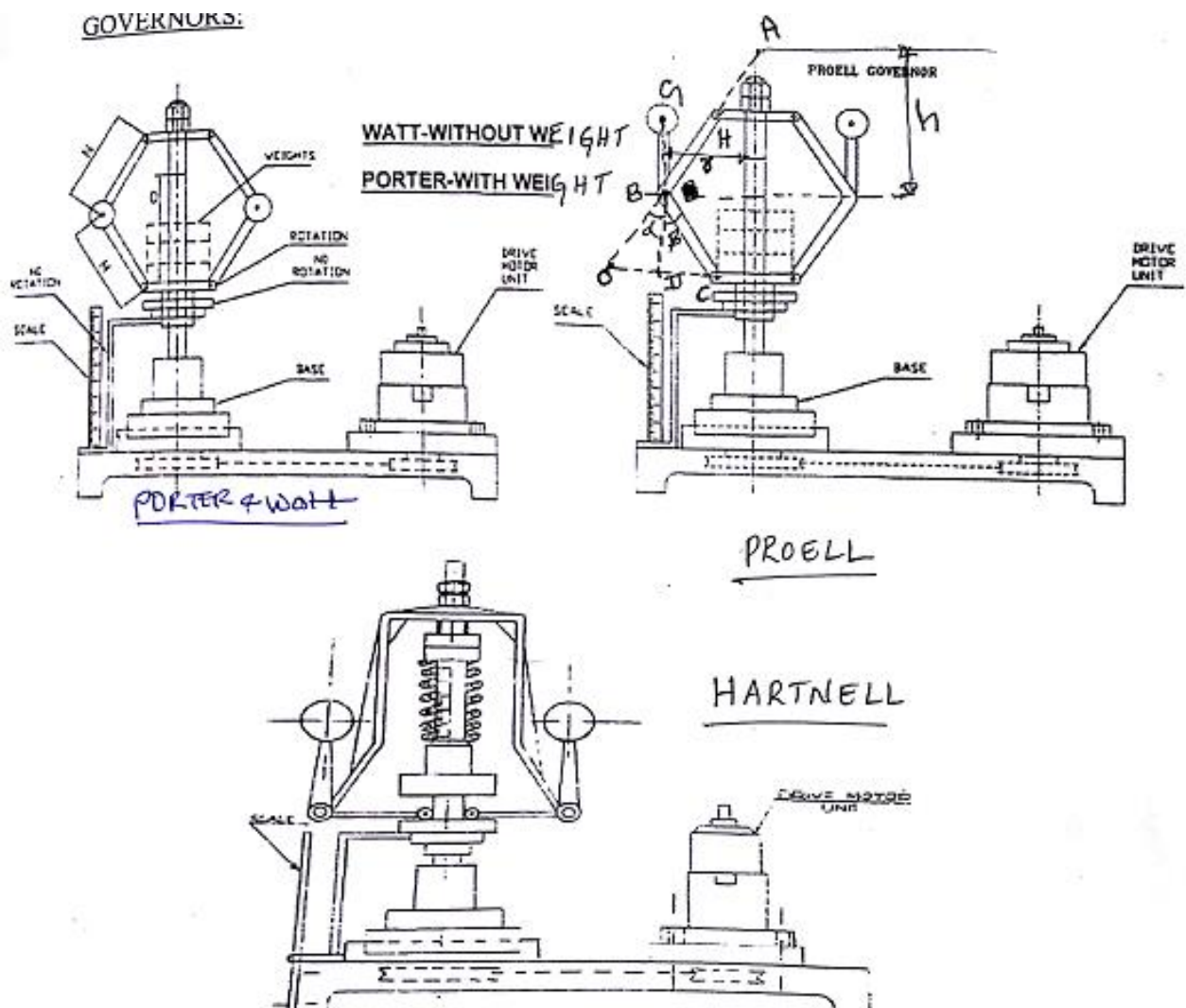
PROELL GOVERNOR:

**Fig 9: Schematic Representation of Porter Governor (without weight Watt), Proell Governors and Hartnel Governor.**

PROCEDURE:

1. The governor mechanism under test is fitted with the chosen rotating weights where applicable and inserted into the drive units, links, arms and masses to the governor are fixed properly
2. Connect the power cord to the electric supply and switch all the power
3. Adjust the variable transformer (i.e dimmer) to the required speed so that the sleeve starts lifting
4. Note down the speed and the scale readings
5. Repeat the experiment for different speeds and note down the corresponding lifts
6. Add extra weights to the centre i.e. to the sleeve assembly and repeat the experiment.
7. Tabulate the readings and calculate the height of the governor and radius of rotations
8. The result may be plotted as curves of speeds against sleeve position.



**OBSERVATIONS AND CALCULATIONS:**

**a) Watt governor and Porter governor(Without mass on sleeve is Watt )**

1. Length of each Arm or link  $L_a=125 \text{ mm}=0.125\text{m}$
2. Weight of each ball,  $w = 425\text{gms}= 0.425\text{Kg}$ .
3. Mass of Sleeve assembly  $M =2.45\text{Kg}$ . And  $g= 9.81 \text{ m/sec}^2$ .

Weight of the sleeve assembly+ weight add on the sleeve,  $W=(24+...) \text{ N}$  **(For porter) For Watt governor** $=2.45\text{Kg}+0=2.45\text{Kg}\times 9.81=24\text{N}$

4. Initial radius of the governor ( Distance from axis of rotation to the ball centre ),  
 $r_o =130\text{mm}=0.130\text{m}$
5. Centrifugal force (controlling force) due to each ball,  $F=$  in Newton's
6. Initial height of governor,  $h_o = 96\text{mm}=0.096\text{m}$ .

**b) HARTNELL GOVERNOR**

1. Stiffness of springs  $S = 3.9\text{KN/m}$
2. Length of vertical arm of bell crank lever,  $a= 0.074\text{m}=74\text{mm}$
3. Length of Horizontal arm of bell crank lever,  $b= 0.111\text{m}=111\text{mm}$
4. Initial radius of rotation,  $r_o= 150\text{mm}=0.15\text{m}$
5. Initial height of the governor= $104\text{mm}=0.14\text{m}$
6. Total mass of the fly balls  $m=0.5\text{Kg}$ , total weight of fly ball= $4.9\text{N}$
7. Mass of sleeve assemble= $2.45\text{Kg}$
8. Weight of the sleeve assembly+ weight add on the sleeve,  $W=(2.45\text{Kg}+0.5\text{Kg}) \times 9.81=-----\text{N}$

**Watt Governor :TABULAR COLUMN 6 (Compare Exp speed and Theoretical Speed)**

Type of Governor	Sl No	Load 'W' In Kg	Governor Speed 'N' rpm(Expermental)	Sleeve Lift 'X' in mm	Radius of Rotation 'r' in m	Height of the Governor 'h' in m	Controlling force 'F' in newtons	Equilibrium Speed 'N <sub>e</sub> ' in rpm(Theoritic al)
Watt Governor	1							
	2							
	3							

**FORMULAE USED:**

**a). WATT GOVERNOR**

1. Height of the governor,  $h = h_0 - \frac{X}{2}$ , Where X = sleeve lift in mm.
2.  $\cos \alpha = \frac{h}{L_a}$  (in degree).
3. Radius of rotation,  $r = 0.05 + L \sin \alpha$
4. Centrifugal force (controlling force) due to each ball,  $F = M\omega^2 r$  in N  
Where in  $\omega = \frac{2\pi N}{60}$  in rad/sec.
5. Equilibrium speed  $N_e = \frac{60}{\pi} \sqrt{\frac{g}{h}}$   
Where in  $K = \frac{\tan \beta}{\tan \alpha} = 1$ , since  $\alpha = \beta$ ,  $f = 0$  (frictional force is neglected)
6. Sensitiveness of the governor  
$$\frac{N_2 - N_1}{\frac{N_1 + N_2}{2}}$$
7. Effort of the governor = Q = (m+M) x C, where in  $C = \frac{N_2 - N_1}{N_1}$
8. Power,  $P = h \times \left[ \frac{M}{2} \times (1+K) + m \right] \times \frac{4xc^2}{1+(2c)}$  in W

RESULT : The radius of the rotating ball increases as controlling force increases.

**b). PORTER GOVERNOR**

**Aim:** TO conduct experiment on Porter governor and determine frictional resistance at the sleeve, centrifugal force on the balls and draw the controlling force diagram.

**Apparatus:** Porter governor, Tachometer and measuring tap

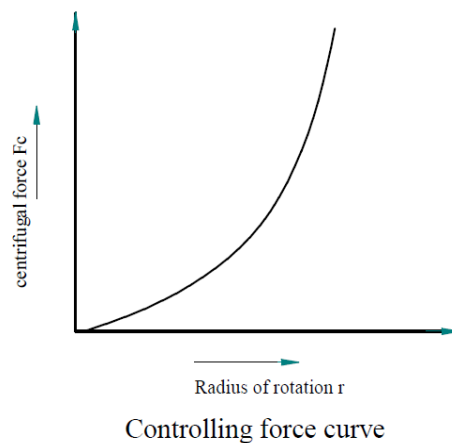
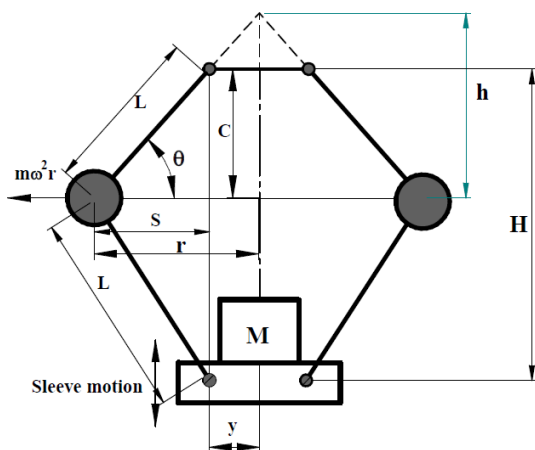

**Observations:**

1. Mass of governor fly balls  $m=0.425\text{Kg}$
2. Mass of sleeve  $M= 2.45+1.5=3.95 \text{ Kg}$
3. Length of upper links = Length of lower links  $L= 0.125 \text{ meters}$
4. Offset of links from axis of rotation  $y = 0.054 \text{ meters}$
5. Initial distance between top & bottom pivots  $H= 0.185\text{meters}$

**PORTER GOVERNOR: TABULAR COLUMN**

Trial No	Speed 'N' Rpm	Sleeve Lift 'x' meters	Distance 'c' meters	Distance 's' meters	Radius of rotation 'r' meters	Angle 'θ' degrees	Height of governor 'h' meters	Frictional Force 'f' Newton	Centrifugal force 'F <sub>c</sub> ' Newton	Effort 'E' Newton	Power P, Nm
1											
2											
3											

**Formulas used for calculations**

1. Distance  $c = \left( \frac{H}{2} - \frac{x}{2} \right)$  (in Meters).
2. Distance  $s = \sqrt{(L^2 - c^2)}$  (in Meters).
3. Radius of rotation  $r=(y + s)$  meters where  $y$ =offset of links
4. Angle  $\theta = \sin^{-1}\left(\frac{c}{L}\right)$  (in Meters).
5. Height of governor  $h= r \tan \theta$   
Frictional force as equilibrium of a speed of a proell governor with equal offset links is  

$$N^2 = \left\{ \frac{mg + (Mg + f)}{mg} \right\} \frac{895}{h}$$
 (in Rpm)  
 Hence  $f = \frac{N^2 mgh}{895} \left( \frac{c + e}{c} \right) - (m + M)g$
6. Effort of the governor is the mean force exerted at the sleeve for a fractional change in speed.  
 $E=0.01(Mg+mg+f)$  for 1% change in speed.
7. Power =Effort x Sleeve lift= $E \times x$ -----Nm
8. Angular velocity  $\omega = \left( \frac{2\pi N}{60} \right)$  rad/sec
9. Centrifugal force or controlling force  $F_c = m\omega^2 r$  Newton
10. **GRAPHS:** Controlling force curve

c). PROELL GOVERNOR.

**Aim:** TO conduct experiment on proell governor and determine frictional resistance at the sleeve, centrifugal force on the balls and draw the controlling force diagram.

**Apparatus:** Proell governor, Tachometer and measuring tap

**Observation**

1. Mass of governor fly balls  $m=0.425\text{Kg}$
2. Mass of sleeve  $M= 2.45+1.5=3.95\text{Kg}$
3. Length of upper links =  $L = 0.125$  meters
4. Offset of links from axis of rotation  $y = 0.054$  meters
5. Extension of links which carry rotating masses  $e = \text{-----}$  meters
6. Initial distance between top & bottom pivots  $H= 0.185\text{meters}$

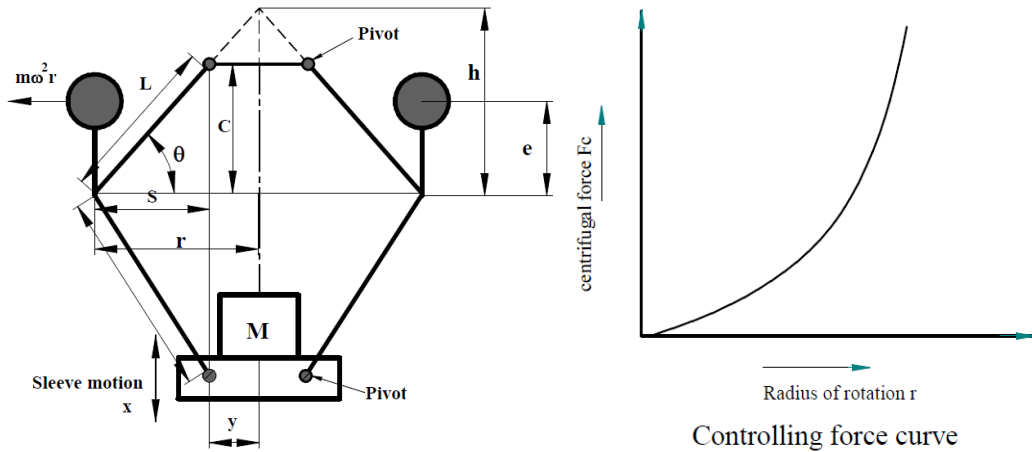

**PROELL GOVERNOR: TABULAR COLUMN**

Trial No	Speed 'N' Rpm	Sleeve Lift 'x' meters	Distance 'c' meters	Distance 's' meters	Radius of rotation 'r' meters	Angle 'θ' degrees	Height of governor 'h' meters	Frictional Force 'f' Newton	Centrifugal force 'Fc' Newton	Effort 'E' Newton	Power P, Nm
1											
2											
3											

**Specimen calculations:**

- Distance  $c = \frac{H}{2} - \frac{x}{2}$  (in Meters).
- Distance  $s = \frac{H}{2} - \frac{x}{2} \sqrt{(L^2 - c^2)}$  (in Meters).
- Radius of rotation  $r = (y + s)$  meters where  $y =$  offset of links
- Angle  $\theta = \sin^{-1}\left(\frac{c}{L}\right)$  (in Meters).
- Height of governor  $h = r \tan \theta$   
Frictional force as equilibrium of a speed of a proell governor with equal offset links is  

$$N^2 = \frac{c}{(c+e)} \left\{ \frac{mg + (Mg + f)}{mg} \right\} \frac{895}{h}$$
 (in Rpm)  
 $e =$  Length of extension links  
Hence  $f = \frac{N^2 mgh}{895} \left( \frac{c+e}{c} \right) - (m+M)g$
- Effort of the governor is the mean force exerted at the sleeve for a fractional change in speed.  
 $E = 0.01(Mg + mg + f)$  for 1% change in speed.
- Power = Effort x Sleeve lift =  $E \times \text{Sleeve lift} = \text{-----Nm}$
- Angular velocity  $\omega = \left( \frac{2\pi N}{60} \right)$  rad/sec
- Centrifugal force or controlling force  $F_c = m\omega^2 r$  Newton

**d). HARTNELL GOVERNOR**

**Aim:** TO conduct experiment on Hartnell (Spring controlled) and determine frictional resistance at the sleeve, centrifugal force on the balls and draw the controlling force diagram.

**Apparatus:** Hartnell Governor, Tachometer and measuring tap

**Theory:**

It is a spring type governor and much more sensitive than porter and proell governor. In this governor the balls are controlled by spring which is mounted on the spindle axis. It consists of the casing in which the pre-compressed spring is housed so as to apply the force on the sleeve. There are two bell crank levers and each of them carries a ball at one of the ends and the roller at another end, both are fitted on the frame of the casing. The casing along with spring and frame rotates about the spindle axis. When the speed of the governor increases then the balls fly out away from the axis, bell crank lever moves on the pivot and then the roller end lifts the sleeve against force. This movement is then transferred to the throttle of the engine. We can also adjust the force just by tightening it. In this  $a$  represents the vertical arm of the bell crank lever and  $b$  represents the horizontal arm of the bell crank lever,  $W$  is the weight of the sleeve,  $w$  is the weight of the ball and  $s$  is the spring force exerted on sleeve. For deriving the relation we take half of the combined weight exerted by sleeve and spring.

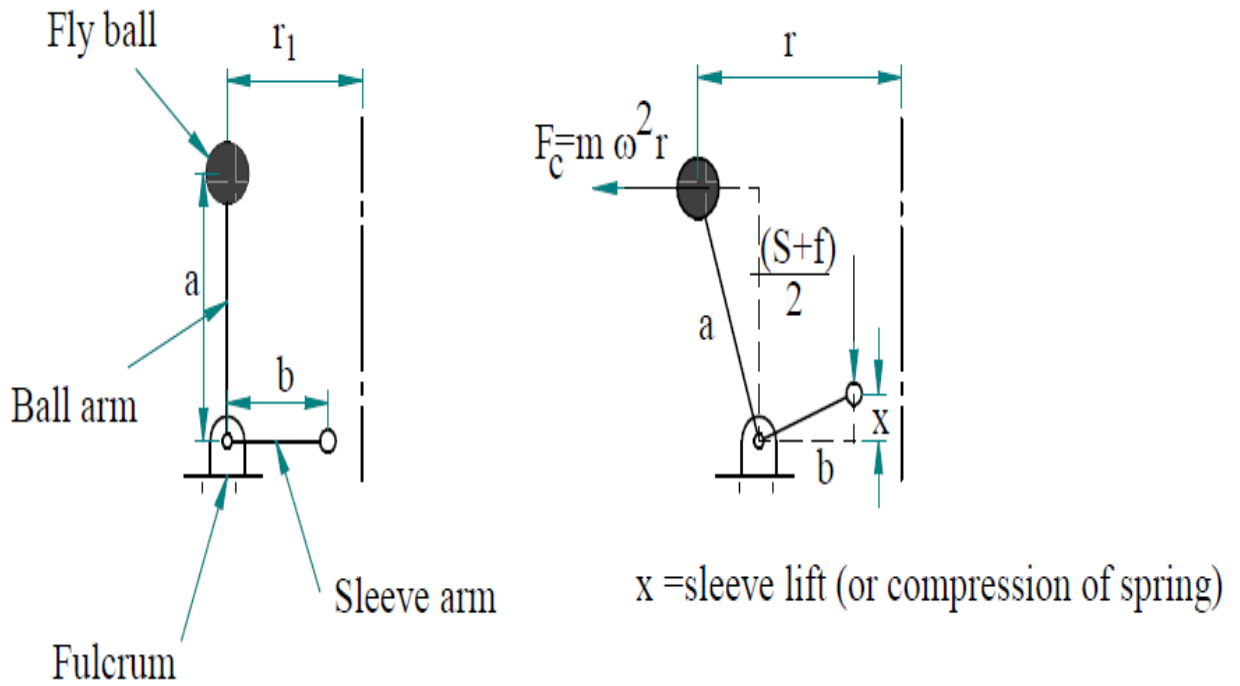

**Observations:**

1. Mass of governor fly balls  $m=0.425\text{Kg}$
2. Stiffness of the spring,  $k= 3 \text{ kg/cm}= 2943\text{N/m}$
3. Length of vertical (ball arm) link =  $a= 0.074\text{m}$  meters
4. Length of horizontal (sleeve arm) link =  $b= 0.111$  meters
5. Initial radius of rotation  $r_1=0.15$  meters

Trial No	Speed 'N' Rpm	Sleeve Lift 'x' meters	Spring force 'S' Newton	Radius of rotation 'r' meters	Centrifugal force 'Fc' Newton	Frictional Force 'f' Newton	Effort 'E' Newton	Power P, Nm
1								
2								
3								

**Specimen calculations:**

1. Angular velocity of the governor spindle  $\omega = \left( \frac{2\pi N}{60} \right)$  rad/sec
2. Spring force  $S = \text{Stiffness} \times \text{sleeve lift} = k \times x$  N
3. Radius of rotation  $r = x \left( \frac{a}{b} \right) + r_1$  metres where  $r_1 = \text{Initial distance between the governor masses \& the spindle axis (Stationary condition)}$
4. Centrifugal force  $F_c = m\omega^2 r$  Newton where  $m = \text{mass of governor fly balls}$ .
5. frictional force at the sleeve  $= 2F_c \left( \frac{a}{b} \right) - (S)$
6. Effort of the governor is the mean force exerted at the sleeve for a fractional change in speed.  $E = 0.01(Mg + S + f)$  for 1% change in speed.
7. Power  $= \text{Effort} \times \text{Sleeve lift} = E \times x = \text{-----Nm}$
8. Controlling force curve

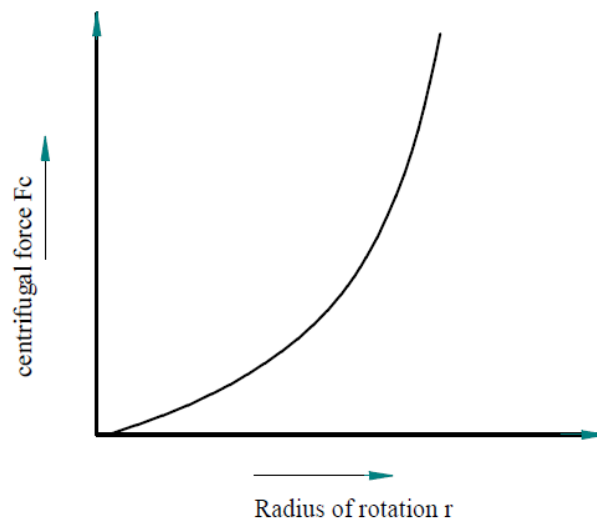

Controlling force curve

**PART-B**

Exp No:-01

Date : \_\_ / \_\_ / 202

**DETERMINATION OF FRINGE CONSTANT OF PHOTO-ELASTIC MATERIAL USING;****a) Circular disc subjected to diametral compression.**

AIM: To calibrate the Photo elastic model (circular disk) under Diametral compression.

EQUIPMENT/APPARATUS REQUIRED:

Circular Poliriscopes with Accessories (Photo elastic Bench), Photo elastic model in the form of a circular disc, Weights(load cell).

TARDY'S METHOD

This method is used for measuring fractional fringe order by compensation at any desired point.

There is every possibility that your point of interest may not exactly on an integral fringe. In such case fractional fringe order may be found out by this method.

1. Confirm that both the pointers are reading zero.
2. Confirm that polariscope is in circular polariscope arrangement.
3. Rotate all four plates by an angle equivalent to the Isoclinic value of the point of interest.
4. Now the main pointer will read Isoclinic value but the pointer on the analyzer will still read zero.
5. Identify the fringe order on both sides of the point of interest.
6. Now rotate analyzer only in any direction till you get a fringe over the point of interest. Either lower order fringe or higher order fringe will move towards the point of interest. After you get a fringe over this point read the scale by pointer on the analyzer (fractional scale). If lower order fringe has moved to the point then add this fraction to lower order fringe number. If higher order fringe has moved to the point then subtract the fraction from higher order fringe number. The result will be fractional fringe order of the point of interest.



EXPERIMENT SETUP: The arrangement of loading as shown in fig below.

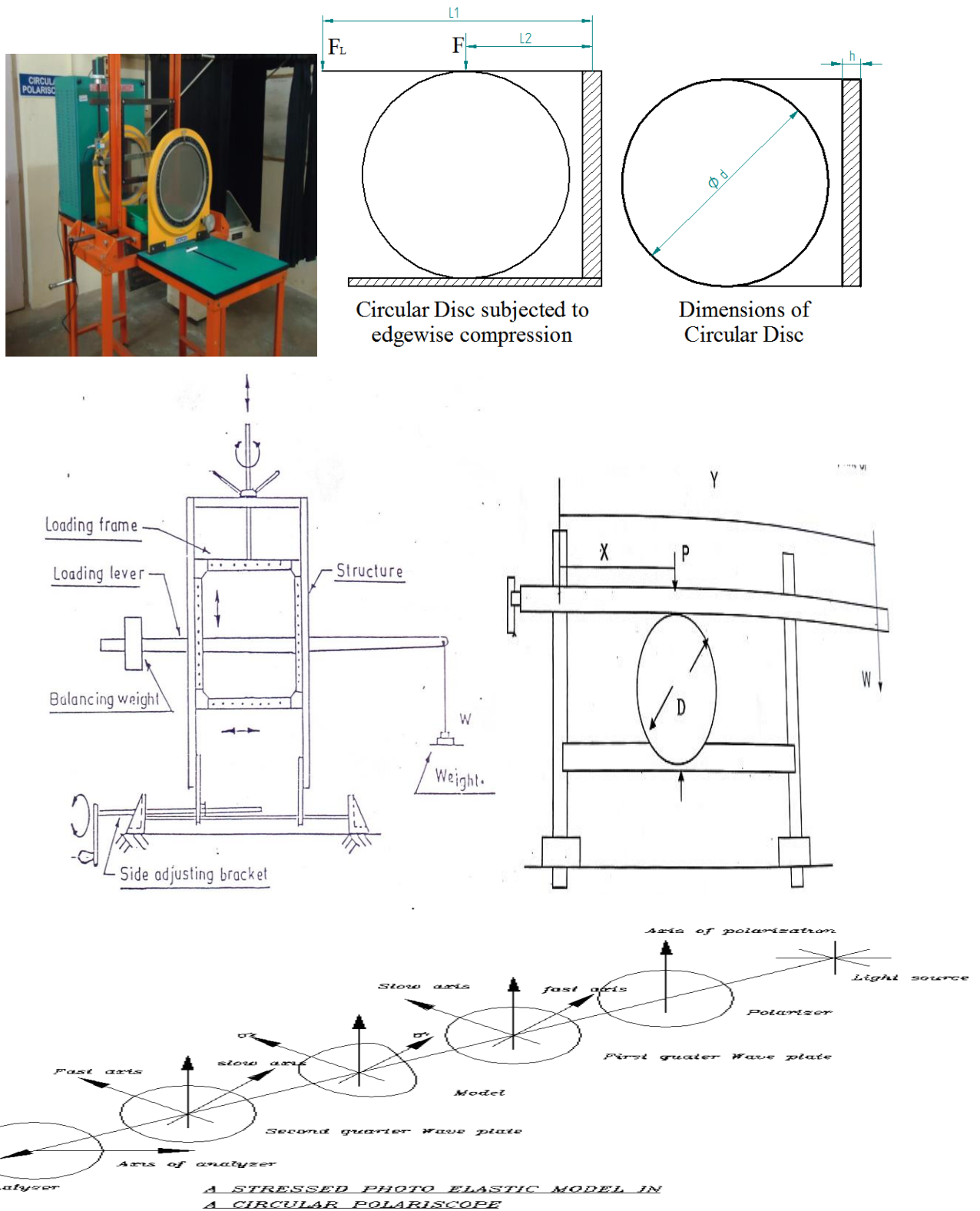

Fig 6: Schematic Layout of Diffused light research polariscope(digital)

**PROCEDURE:**

1. Measure disc diameter 'D' and mark the point of interest.(for calibration take the centre point)
2. Fringe order is determined by using Tardy's method.
3. Determine the direction of stress  $\sigma_1$  and  $\sigma_2$  using dark field polar scope.
4. Note down the principle angle of stresses at a point of interest.
5. Arrange polarizer and analyzer along the principle axis at point of interest
6. Determine higher order and lower order fringe  $N_h$  and  $N_L$  respectively around the point.
7. In order to establish the fringe order uses white light so that zero order light fringe will appear black and all other appear colored. The first order will appear as a tint of passage between red and bluish green by using white light, the colour and order N.
8. After finding zero order fringes, switch over to monochromatic light so that all fringes appears black.
9. Rotate the analyzer by keeping all other elements (Polarizer, quarter wave plates) at their position through an angle  $\alpha$ , till lower order fringe  $N_L$  passes through the given point, then  $N_f = N_L - \alpha/180$
10. As cross check, rotate the analyzer in opposite direction through the given point then  $N_f = N_L - \beta/180$ .
11. The mean value of  $N_f$  is taken as N
12. From above the values of P and for each value of P find  $N_f$  at point of interest.

**SPECIFICATIONS:**

- Diameter of the Specimen : d = .....mm
- Thickness of the Specimen : h = .....-mm
- Distance from the fulcrum to the Applied load : l = .....mm
- Distance from fulcrum to the center of the specimen:  $l_1 = \dots\dots\dots$ mm

**OBSERVATION TABLE:**

Sl. No	Fringe Order (N)	Load applied (W)		Effective load (P)	Slope of line ( $\Delta P/\Delta N$ )	Material fringe constant ( $f_\sigma$ )
		Kg	N	N	N/fringe	N/mm/fringe
1						
2						
3						
4						
5						

**GRAPH: P v/s N (linear)**

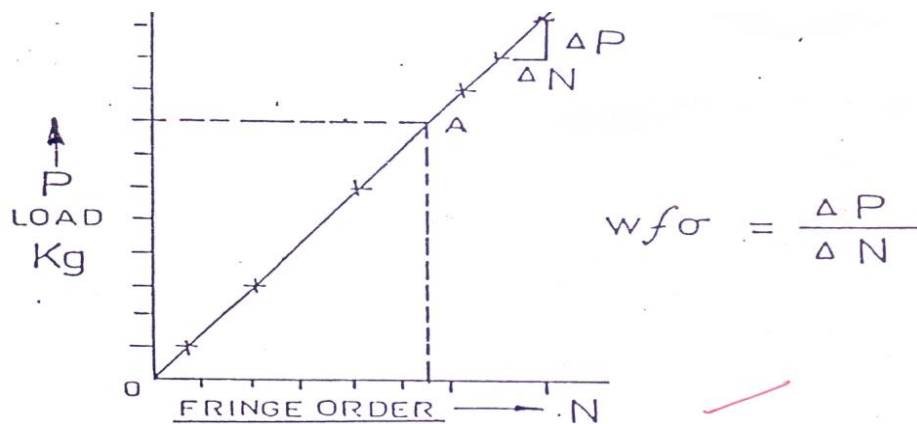

**SPECIMEN CALCULATIONS:**

Effective load  $P = W \times l/l_1 = \dots\dots\dots N$  (By taking moments)(for old setup)

Slope from graph =  $\Delta P/\Delta N = \dots\dots\dots N/fringe$

Material fringe constant ( $f_\sigma$ ) =  $(8/\pi d) (\Delta P/\Delta N) = \dots\dots\dots mm/fringe.$

**Result and conclusion:** The material fringe value of the given Photoelastic material(**Circular disc subjected to diametral compersion**) is \_\_\_\_\_

\_\_\_\_\_N/mm/fring

**DETERMINATION OF FRINGE CONSTANT OF PHOTO-ELASTIC MATERIAL USING;  
(OLD EXPERIMENT)**

EXPERIMENT SETUP: The arrangement of loading as shown in fig below.

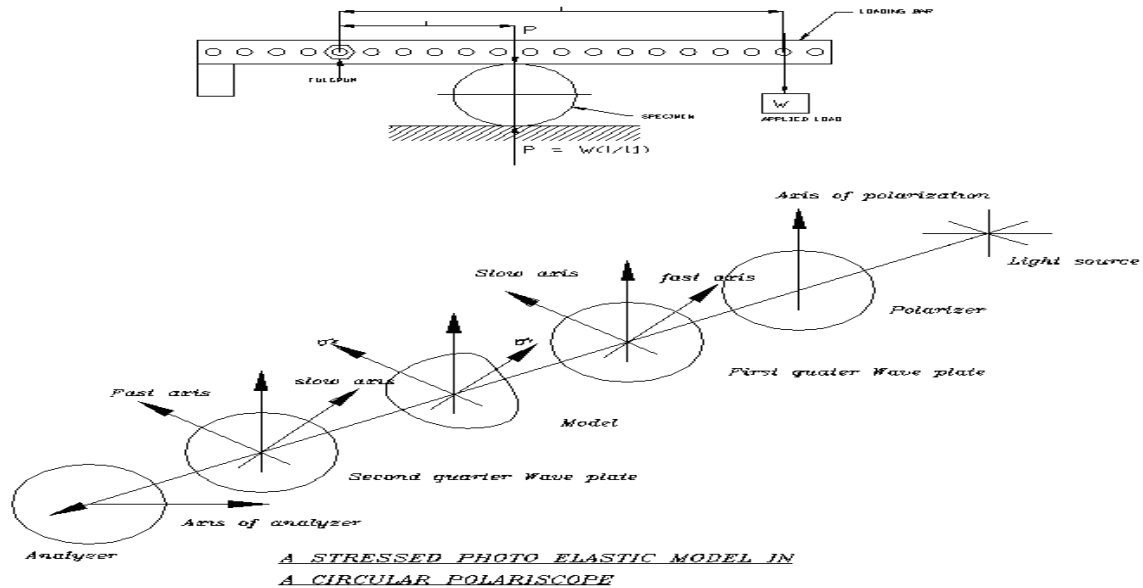

PROCEDURE:

1. Hang a pan to the loading bar for placing weights for loading so as to make the lever horizontal.
2. Place the model between the loading arm and the bottom surface of the frame.
3. Measure the distances from the fulcrum to the specimen ( $l_1$ ) and fulcrum to the load 'W' ( $l_2$ ).
4. Observe for each fractional loads placed on the pan, the specimen through the analyzer.
5. Determine the effective loads required for getting integral fringe orders (0,1,2,3.) at the center of the circular disk and tabulate.
6. Draw the graph between effective load Vs fringe pattern (linear graph)
7. Calculate the slope of the line.
8. Calculate material fringe constant by using the equation (3)

**SPECIFICATIONS:**

Diameter of the Specimen : d = -----mm  
 Thickness of the Specimen : h = -----mm  
 Distance from the fulcrum to the Applied load : l = -----mm  
 Distance from fulcrum to the center of the specimen: l<sub>1</sub>= -----mm

**TABULAR COLUMN:**

Sl. No	Fringe Order (N)	Load applied (W)		Effective load (P) N	Slope of line (Δ P/Δ N) N/fringe	Material fringe constant (f <sub>σ</sub> ) N/mm/fringe
		Kg	N			

**GRAPH:** P v/s N (linear)

**SPECIMEN CALCULATIONS:**

Effective load P = W x l/l<sub>1</sub> = -----N (By taking moments)  
 Slope from graph = ΔP/ΔN = -----N/fringe  
 Material fringe constant (f<sub>σ</sub>) = (8/πd) (ΔP/ΔN) = -----mm/fringe.

**CONCLUSION:** The material fringe value of the given Photoelastic material is \_\_\_\_\_N/mm/fring

## b) Pure bending Specimen (Calibration of four point bending specimen)

EXPERIMENT SETUP: The arrangement of loading as shown in fig below.

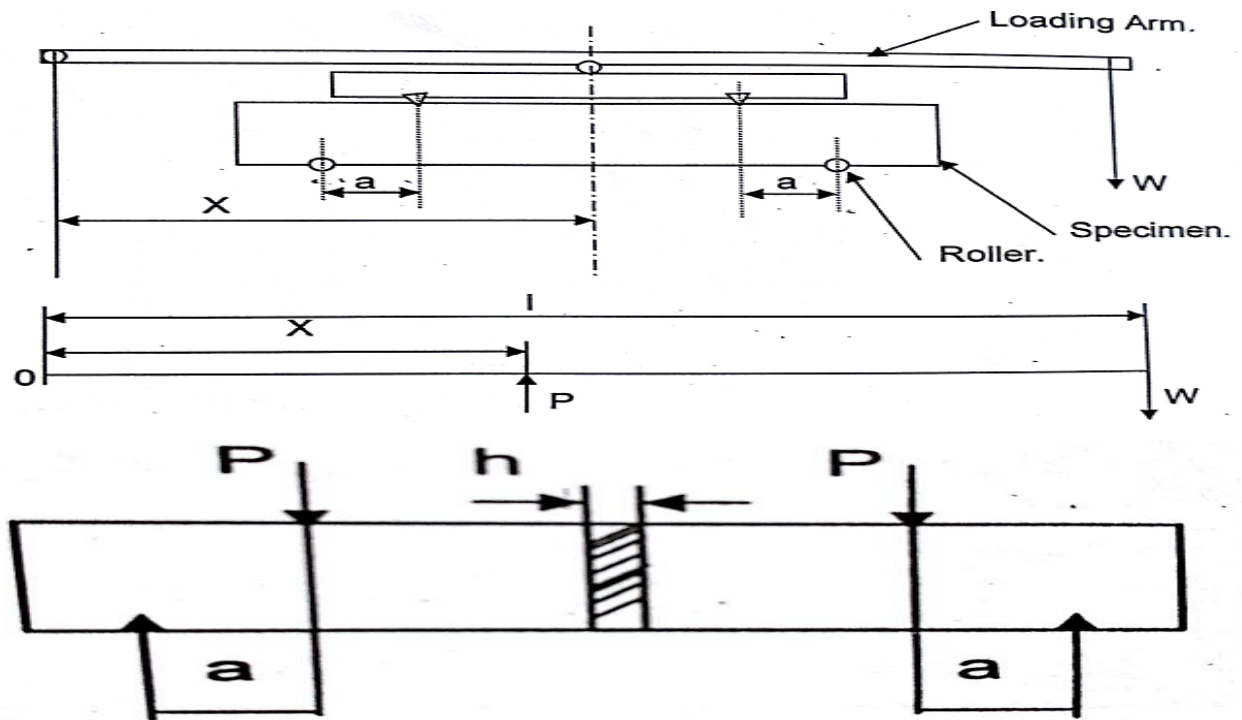

Fig 7: Setup for pure four point bending.

PROCEDURE:

- 1) Make the set as shown in the Fig.
- 2) Take the measurement as given in the observation table.
- 3) Apply known weight at the end of the loading arm( $W$ )
- 4) Mark out the point of interest in the area of uniform bending moment.
- 5) Find out the fringe order " $N$ " at the point of interest.
- 6) Find out value of  $f_{\sigma}$  from calculation given.
- 7) Plot a graph of " $N$ " against " $P$ ".

OBSERVATION:

- 1) Length of the loading arm ( $l$ ) in mm =
- 2) ' $W$ ' applied weight in Kgs
- 3) Distance between fulcrum and center of application of load ( $X$ ) in mm=
- 4) Distance between support and point load ( $a$ ) in mm =
- 5) Width of specimen ( $w$ ) in mm=
- 6) Thickness of the specimen( $h$ ) in mm=
- 7) Fringe order at the point of interest ( $N$ ) =

**OBSERVATION TABLE:**

Sl.No	Actual load "W" in N	Distance between Fulcrum and center point "X" in mm	Load applied at point "P" in N	Fringe order "N"	$\sigma_b = \sigma_1$	$f_\sigma$	Mean $f_\sigma$
1							
2							
3							
4							
5							

**GRAPH: P v/s N (linear)**

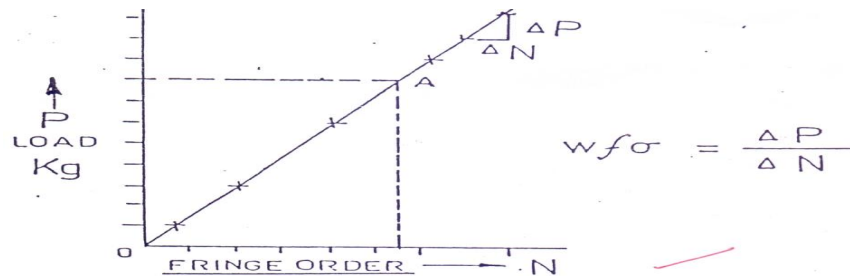

**Calculations:**

1) To find the Value of 'P'. Let W be the weight at the end of the loading arm. Taking moment about point 'O' (Refer Fig.) for equilibrium, we have,

$$W \cdot l = P \cdot X$$

Therefore,  $P = \frac{W \cdot l}{X}$

2) The uniform bending moment 'M' in the middle portion of the beam is given by  $M = P \cdot a$   
Bending stress in the beam is given by

$$\sigma_b = \frac{M}{I} y \quad \text{OR} \quad \frac{M}{Z}, \quad \text{where } I = \frac{1}{12} h w^3 \quad \text{and } y = \frac{W}{2}$$

$$\text{Therefore } \sigma_b = \frac{M}{\frac{1}{12} h w^3} \cdot \frac{W}{2} = \frac{6M}{h w^2} = \frac{6Pa}{h w^2}$$

This bending stress is principal stress  $\sigma_1$

Therefore  $\sigma_1 = \sigma_b = \frac{6Pa}{h w^2}$       $\sigma_2 = 0$

From stress optics law

$$\sigma_1 - \sigma_2 = \frac{N f_\sigma}{h} = \frac{6Pa}{h W^2} \quad \text{Therefore } f_\sigma = \frac{6Pa}{N W^2} = \left[ \frac{P}{N} \right] \frac{6a}{W^2}$$

For more than one reading a graph of  $\epsilon$ (x-axis) against P(y-axis) may be plotted. The graph is a straight line whose slope will give mean value of  $p = P/N$

Formulas used:

1) Load applied at point  $P = \frac{W * l}{X}$  (for old setup)

2) Uniform bending moment  $\sigma_b = \frac{6Pa}{hw^2}$

3) Bending stress is principal stress  $\sigma_1 = \sigma_b = \frac{6Pa}{hw^2}$   $\sigma_2 = 0$

4) Stress optics law  $f_\sigma = \frac{6Pa}{NW^2} = \left[ \frac{P}{N} \right] \frac{6a}{W^2}$

**Result and conclusion:** The material fringe value of the given Photoelastic material (**four point bending specimen**) is \_\_\_\_\_ N/mm/fring



Exp No:02

Date: \_\_ / \_\_ / 202

**DETERMINATION OF STRESS CONCENTRATION FACTOR (K)**

AIM: To determine the stress concentration for a circular disc with a circular hole at the Center under diametral compression.

EQUIPMENT/APPARATUS REQUIRED: Circular Poliriscope with Accessories (Photoelastic Bench), Photoelastic model in the form of a circular disc with central hole, Weights varies 50gms to 10kg.

THEORY: The stress distribution along the horizontal diameter in a circular disc under compression is given by Circular disc with central hole subjected to pure compression

Stress concentration is the irregularity of stress distribution caused by abrupt changes in cross section. This stress concentration is exposed in the form of stress concentration factor  $K_t$  whose value is given by

$$K_t = \frac{\text{Max.stressatpoint( Actualstress)}}{\text{No min alstressatthepoint}} = \frac{\sigma_a}{\sigma_n}$$

$\sigma_a$ =Actual stress considering stress concentration at a point and  $\sigma_n$  = Nominal stress at the same point .

The nominal stress is stress obtained from the simple formula of stress and strain  $K_t$  depends upon the material and geometry of the part. Stress concentration may be present at fillets, notches, holes, shoulders, threads or at any irregularity such as file scratch or number of stampings.

The stress concentration factor may be found out by the use of photoelastic Circular specimen with circular hole at the centre the specimen may be loaded in tension as shown in the fig.

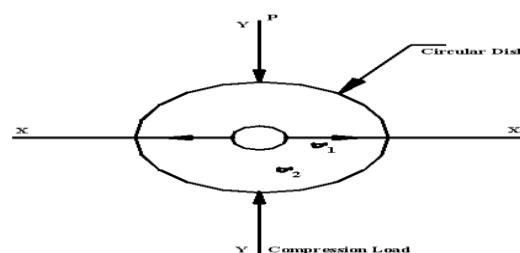

Estimating the fringe value is called **Calibration**.

**EXPERIMENT SETUP:** The arrangement of loading as shown in fig. Below.

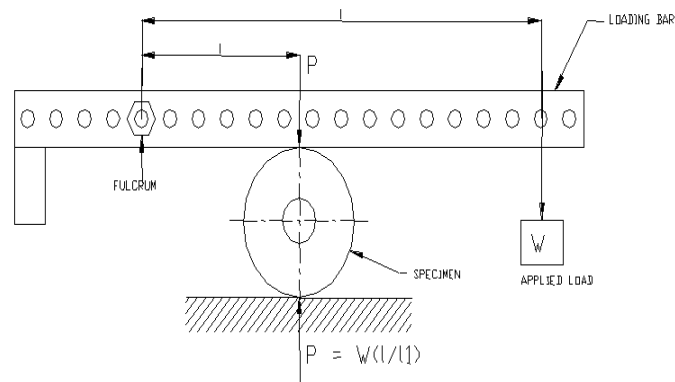

**Fig 8: Circular disc with central hole subjected to diametral compression**

**PROCEDURE:**

1. Load the specimen as per the set up.
2. Find the direction of the principal stress by using plane polariscope arrangement.
3. Set the Polariscope to circular arrangement (Dark field) and Using Tardy's method determine the fringe order E at the given point A.
4. According to stress optics law  $\sigma_1 - \sigma_2 = \frac{Nf_{\sigma}}{h}$
5. The point A is situated at the free boundaries one of the principal stress normal to the boundary is zero. So isochromatic data yields directly the the value of other principal stress. Thus  $\sigma_1 = \sigma_a$ , and  $\sigma_2 = 0$  thus the equation reduces to  $\sigma_a = \frac{Nf_{\sigma}}{h}$
6. Knowing the fringe order E and material fringe value  $f_{\sigma}$ ,  $\sigma_a$  will be calculated.
7.  $K_t = \frac{\sigma_a}{\sigma_n}$

**OBSERVATION:**

Diameter of the specimen: D = mm  
 Diameter of the hole: d = mm  
 Thickness of the specimen: h = mm  
 Distance from the fulcrum to the Applied load: l = mm  
 Distance from fulcrum to the center of the specimen:  $l_1 =$  mm

**TABULAR COLUMN FOR MATERIAL FRINGE CONSTANT ( $f_\sigma$ ):**

Sl. No	Fringe order (N)	Load applied (W)		Effective load (P) N	Slope of line ( $\Delta P/\Delta N$ ) N/fringe	Material fringe constant ( $f_\sigma$ ) N/mm/fringe
		Kg	N			

**GRAPH:** P v/s N

**SPECIMEN CALCULATIONS (Formulas used):**

- Effective load  $P = \frac{W * l}{X} = \dots\dots\dots N$  (By taking moments)
- Slope from graph  $\frac{\Delta P}{\Delta N} = \dots\dots\dots N/fringe$
- Material fringe constant  $f_\sigma = \left[ \frac{8}{(D-d)\pi} \right] \frac{\Delta P}{\Delta N} = \dots\dots\dots N/mm/fringe.$
- Nominal stress  $\sigma_n = \frac{P}{(D-d)h} = \dots\dots\dots N/mm^2$
- Maximum induced stress  $\sigma_a = \frac{Nf_\sigma}{h} = \dots\dots\dots N/mm^2$
- Stress concentration factor  $= K_t = \frac{\sigma_a}{\sigma_n} = \dots\dots\dots$

**TABULAR COLUMN FOR STRESS CONCENTRATION ( $K_\sigma$ ):**

Sl No	Fringe No	Load	Nominal stress ( $\sigma_{nom}$ )	Max induced stress ( $\sigma_{max}$ )	Stress concentration ( $K_\sigma$ )
1					
2					
3					
4					

**Result and conclusion:** The material fringe value of the given Photoelastic material is ..... N/mm/fringe. And The Stress concentration factor at the hole for the given Model is S.C.F =

Exp No 3:-

**JOURNAL BEARING**

Date \_\_\_ / \_\_\_ / 202

AIM: Determine the of pressure distribution in Journal bearing for given loading and speed condition

APPARATUS:

1. Journal bearing apparatus with manometers
2. Oil (SAE 40)

THEORY:

Journal or plain bearings consist of a shaft or journal which rotates freely in a supporting metal sleeve or shell. There are no rolling elements in these bearings. Their design and construction may be relatively simple, but the theory and operation of these bearings can be complex. This article concentrates on oil and grease-lubricated full fluid film journal bearings; but first a brief discussion of pins and bushings, dry and semi-lubricated journal bearings, and tilting-pad bearings.

Low-speed pins and bushings are a form of journal bearing in which the shaft or shell generally does not make a full rotation. The partial rotation at low speed, before typically reversing direction, does not allow for the formation of a full fluid film and thus metal-to-metal contact does occur within the bearing. Pins and bushings continually operate in the boundary lubrication regime. These types of bearings are typically lubricated with extreme pressure (EP) grease to aid in supporting the load. Solid molybdenum disulphide (moly) is included in the grease to enhance the load-carrying capability of the lubricant. Many outdoor construction and mining equipment applications incorporate pins and bushings. Consequently, shock loading and water and dirt contamination are often major factors in their lubrication.

Dry journal bearings consist of a shaft rotating in a dry sleeve, usually a polymer, which may be blended with solids such as molybdenum, graphite, PTFE or nylon. These bearings are limited to low-load and low-surface speed applications. Semi-lubricated journal bearings consist of a shaft rotating in a porous metal sleeve of sintered bronze or aluminium in which lubricating oil is contained within the porous metal sleeve of sintered bronze or

aluminium in which lubricating oil is contained within the pores of the porous metal. These bearings are restricted to low loads, low-to-medium velocity and temperatures up to 100°C(210°F).

Tilting-pad or pivoting-shoe bearings consist of a shaft rotating within a shell made up of curved pads. Each pad is able to pivot independently and align with the curvature of the shaft. A diagram of a tilt-pad bearing is presented in figure 1. The advantage of this design is the more accurate alignment of the supporting shell to the rotating shaft and the increase in shaft stability which is obtained

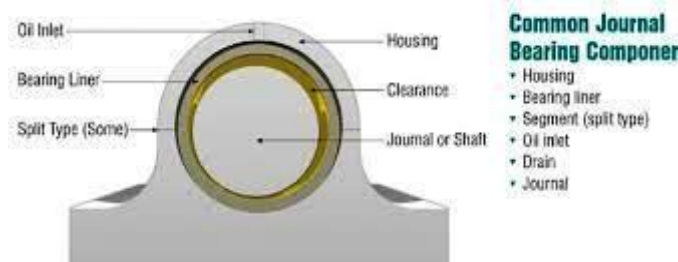

**A TYPICAL JOURNAL BEARING**

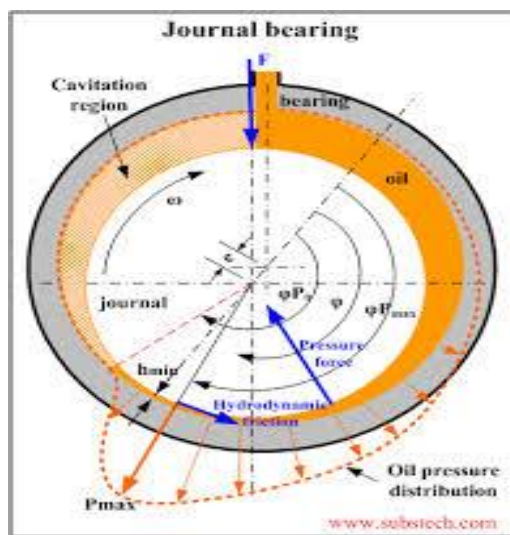

**PRESSURE DISTRIBUTION IN JOURNAL BEARING**

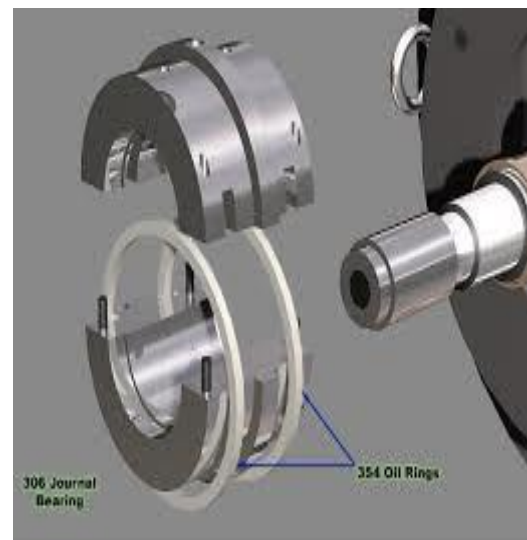

**EXPLODED VIEW OF A JOURNAL BEARING**

**A TYPICAL JOURNAL BEARING**

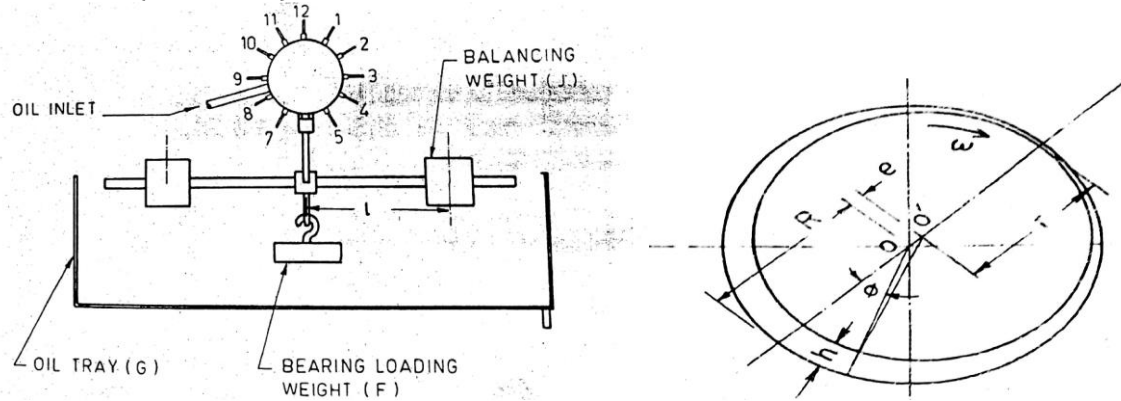

$W$  = speed rotation of journal,  $r$  = radius of journal,  $\delta$  = Radial clearance ( $R-r$ ),  $e$  = eccentricity  
 $OO^1$ ,  $e = n\delta$ ,  $\mu$  = viscosity of oil

**Fig 10: Details of Journal, Bearing and loading arrangement and geometry of the journal bearing.**

#### PROCEDURE:

1. Fill the oil tanker by using the given oil under test and position the tank at the desired height
2. Drain out the air from the tubes on the manometer and check the level
3. See to it that some oil leak is there which is important with respect to the cooling purpose
4. Check the direction of rotation and increase the speed of the motor slowly
5. Set the speed and let the journal run for about half an hour until the oil in the bearing is warmed up and check the steady oil level at various timings
6. Hold the required loads and keep the balancing rod at the required horizontal position by means of moving balancing weight 'j' on the rod and observe the steady levels
7. When the manometer levels have settled down, take the pressure reading on the 1-12 manometers tubes for circumferential pressure distributions and A-B-C-D tubes for axial pressure distributions
8. Repeat the experiment for various speed and loads
9. After the test set the apparatus on zero position and switch off the supply main
10. Keep the oil tanks on lower most position so that there will not be any leakage in the idle period.

#### OBSERVATION:

1. Diameter of the journal (2r) = (d) = 50 mm
2. Diameter of the Beam (2R) = (D) =54 mm
3. Radial Clearance (c) =  $\frac{D-d}{2}$  =
4. Length of the Bearing (L) = 100 mm
5. Absolute viscosity of the oil =  $\mu$  = 0.143 N-s/m<sup>2</sup> (for SAE 40 )
6. Initial pressure = P<sub>o</sub> =
7. Speed of the shaft = N =

**TABULAR COLUMN 9:**

Tube No	Circumferential Pressure Distribution				Radial Pressure Distribution			
	Manometer Pressure Head, P <sub>1</sub> (in cm)				( P <sub>1</sub> -P <sub>o</sub> ), in cm			
	500rpm		800rpm		500rpm		800rpm	
	0.5Kg	1Kg	0.5Kg	1Kg	0.5Kg	1Kg	0.5Kg	1Kg
1								
2								
3								
4								
5								
6								
7								
8								
9								
10								
11								
12								

Axial pressure Distribution								
A								
B								
C								
D								

**Expected Graphs**

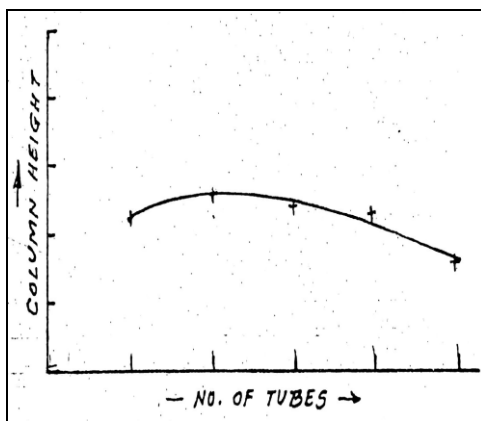

(a) Axial pressure distribution

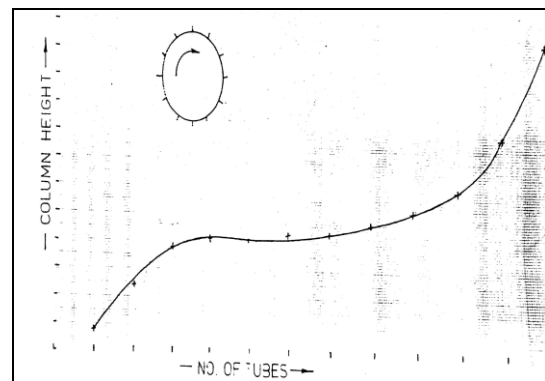

(b) Circumferential Pressure Distribution

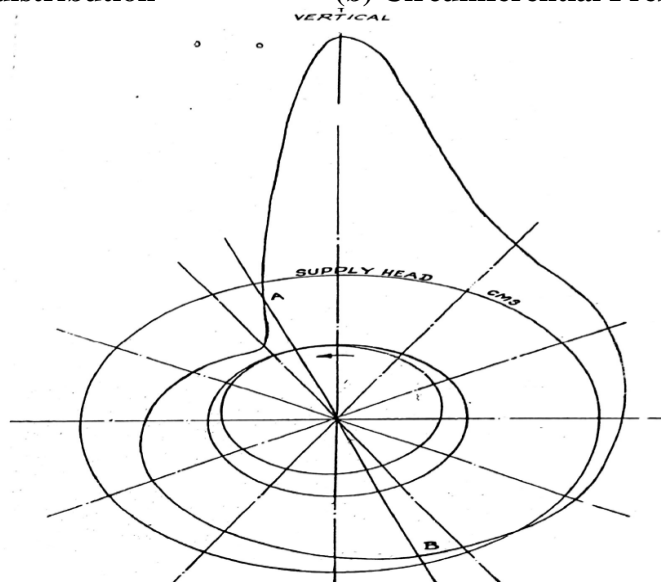

(c) Radial Pressure Distribution polar diagram speed  $N_1$

**Fig 11: Expected Graphs of (a) Axial pressure distribution (b) Circumferential Pressure Distribution (c) Radial Pressure Distribution polar diagram speed.**



AIM: To Determine the Principal Stresses and strains in a member subjected to combined loading using Strain rosettes.

APPARATUS: Panel, Tare, Switch, Cable Conn, Valve, Rosette, Cylinder, Foot Pump

THEORY:

Resistance of a wire of length 'L' and cross sectional area 'A' is given by equation  $R = \delta * L$ , where 'δ' is resistivity of wire material. If such a wire is subjected to strain its resistance will change depending upon change in 'L' and 'A'. In strain gauge technique a very thin wire of the order of 5 to 10 micron diameter is pasted on metal part by means of suitable adhesive. The metal part then subjected to load, which finally results induction of strain in it.

By knowing the strain values, stress values are calculated by using standard strength of material relations. Hence the values of stresses at various points of interest can be found out experimentally, resulting into complete stress picture of the metal part under investigation.

INVESTIGATION PROCEDURE:

For investigating the stresses in the metal part the entire cases can be categorized in two groups –

**i. When direction of stresses is know.**

In first case it is easy to analyze because the direction in which the maximum principal stress occurs is known in certain metal parts, such as Beams, direct tension or torque cases. In such cases strain gauges can be oriented in already known direction and single element strain gauges serve the purpose.

**ii. When direction of stresses is unknown.**

Second case can be treated as generalized case and following exhaustive steps are to be followed in such cases.

- 1) Out of entire machine parts under investigation, critical areas to be decided by the investigator. To decide these critical areas on should study the failure history, nature of loading, nature of fixing boundary conditions etc. related to part under investigation.

- 2) The total number of strain gauges, which are to be pasted at various points on the surface of the part, are to be decided. Here it should be noted that, strain gauges can measure only surface strains and not strain at interior of cross section.
- 3) Single element strain gauges will not serve purpose; hence three elements rectangular type of gauge is used.
- 4) By using proper adhesive and following proper procedure gauges are fixed at various points of interest.
- 5) Strain gauge installation is checked by multi-meter.
- 6) Using multi-channel strain indicator, connection of gauges are done.
- 7) Without loading the machine parts initially balancing of all gauges is done on strain indicator.
- 8) By applying rated pressure on cylinder micro strain values of each gauge are record.
- 9) The experimental setup consists of a cylinder which can be pressurized by air using foot pump. The pressure can be measured with the help of pressure gauge mounted on foot pump.
- 10) Figure shows three gauge elements plotted at arbitrary angle  $\theta$  A,  $\theta$  B and  $\theta$  C relative to X and Y Planes.  $\epsilon_1$ ,  $\epsilon_2$  and  $\epsilon_3$  are three values of micro strains recorded on one rectangular rosette by using multi-channel strain indicator.

**Experimental setup Shown in Fig**

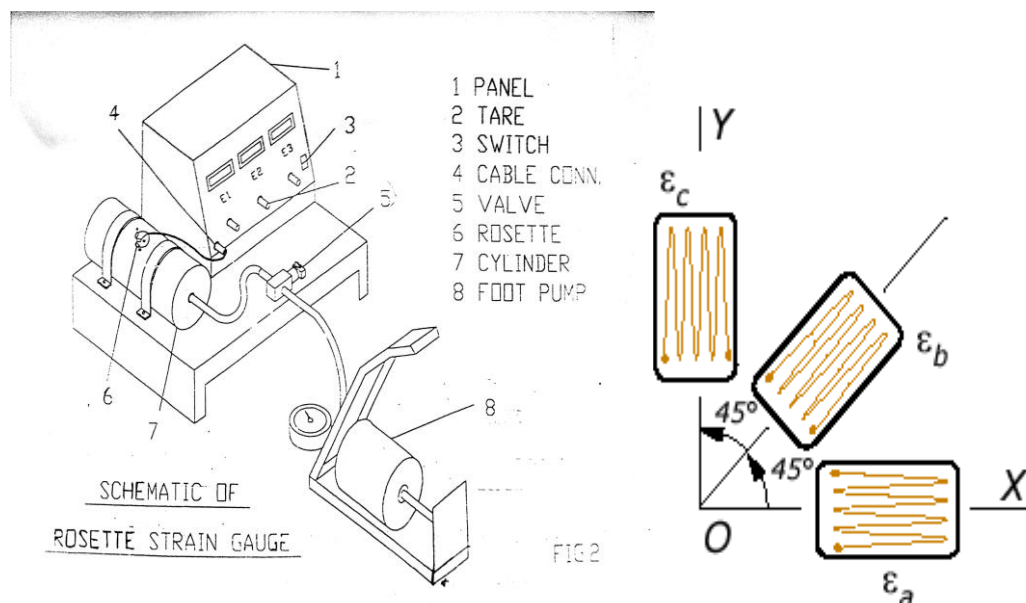

**Fig 12: Schematic of Rosette strain gauge.**

## Formulas and calculation

**1. Principal Strains;**

If the strain values are desired, then following equation is used

$$a). \epsilon_{\max} = \frac{1}{2}(\epsilon_1 + \epsilon_3) + \frac{1}{2}\sqrt{\{(\epsilon_1 - \epsilon_3)^2 + [(2\epsilon_2 - (\epsilon_1 + \epsilon_3))]^2\}}$$

$$b). \epsilon_{\min} = \frac{1}{2}(\epsilon_1 - \epsilon_3) - \frac{1}{2}\sqrt{\{(\epsilon_1 - \epsilon_3)^2 + [(2\epsilon_2 - (\epsilon_1 + \epsilon_3))]^2\}}$$

$$c). \text{Maximum shear strain } \gamma_{\max} = \sqrt{\{(\epsilon_1 - \epsilon_3)^2 + [(2\epsilon_2 - (\epsilon_1 + \epsilon_3))]^2\}}$$

Where  $\epsilon_{\max}$  and  $\epsilon_{\min}$  are principal strains.

Angle made by 'Principal strains' with X direction is given by,

+ve sign for  $\epsilon_{\max}$  (major principal strain) and - ve sign for  $\epsilon_{\min}$  (Minor principal strain).

**(Note: if any of the individual strain values are negative, substitute them as it is)**

**2. Principal Stresses;**

If the Stress values are desired, then following equation is used

$$a). \sigma_{\max} = \frac{E}{1 - \mu^2} (\epsilon_{\max} + \mu\epsilon_{\min}) \text{ in Mpa}$$

$$b). \sigma_{\min} = \frac{E}{1 - \mu^2} (\epsilon_{\min} + \mu\epsilon_{\max}) \text{ in Mpa}$$

$$c) \text{Maximum shearing stress } \tau_{\max} = \frac{E}{2(1 + \mu)} \gamma_{\max} \text{ in Mpa}$$

**3. Principal angle**

Where 'θ' is the angle made by principal stress and principal stress direction.

$$1). \theta_1 = \frac{1}{2} \tan^{-1} \left( \frac{2\epsilon_2 - (\epsilon_1 + \epsilon_3)}{\epsilon_1 - \epsilon_3} \right) \text{ in degrees and } \theta_2 = \theta_1 + 90^\circ$$

**Theoretical calculation**

$$\epsilon_{\text{Max}} = \frac{PD}{2TE}$$

Where P=Pressure in N/mm<sup>2</sup>

D=Diameter of cylinder in mm

T=Thickness of cylinder in mm

E=Young's Modulus=2\*10<sup>5</sup> N/mm<sup>2</sup>

**Tabular Column**

SI No	Pressure(Kg/Cm <sup>2</sup> )	Micro Strain ' $\epsilon_1$ ' x(10 <sup>-6</sup> )	Micro Strain ' $\epsilon_2$ ' x(10 <sup>-6</sup> )	Micro Strain ' $\epsilon_3$ ' x(10 <sup>-6</sup> )	Major Principal strain $\epsilon_{\text{max}}$	Minor Principal strain $\epsilon_{\text{min}}$	Major Principal stress $\sigma_{\text{max}}$	Minor Principal stress $\sigma_{\text{min}}$	$\theta_1$	$\theta_2$
1	3									
2	4									
3	5									

**Viva Questions**

1. What is bearing?
2. Give the classification of bearings.
3. Define pressure.
4. Differentiate between Stress and Pressure.
5. What is lubrication?
6. Define Viscosity.
7. List the properties of a good lubricant.
8. What is a journal?
9. What is SAE 1040?
10. What is a strain gauge? Mention different of strain gauge.
11. What is photo elasticity?
12. Define stress concentration factor?
13. List the reasons to cause the stress concentration factor.
14. Define principal Stress and principal strain?
15. Define Young's modulus, modulus of rigidity, Poisson's ratio.
16. What do you mean by gauge factor?
17. What is material fringe constant?
18. Define vibrations?
19. What are the different types of vibrations?
20. Define stiffness and write the unit of stiffness.
21. What is logarithmic decrement?
22. Define Damping Ratio?
23. What is Critical Damping?
24. Define Damping Co-efficient?
25. What is a governor?
26. What are the different types of Governors?
27. Define centrifugal Force?
28. What is controlling force?
29. Mention the function of the governor?
30. Define power of a governor?
31. What is effort of a governor?

32. Define couple.
33. What is balancing of machines? Why it is required?
34. What do you mean by Whirling of Shaft?
35. Define critical speed of a shaft?
36. List the applications of journal bearing?
37. What is natural frequency?
38. List the advantages and disadvantages of vibrations?
39. What is calibration?
40. What is the use of strain rosette?
41. Differentiate between Undammed and damped vibrations.
42. List the different types of design procedures.
43. Mention the methods to minimize the stress concentration.
44. Define nominal stress and true stress?
45. Define Bearing characteristic number and bearing modulus for Journal bearing?
46. Explain co-efficient of friction for journal bearing?
47. What is meant by Hydrodynamic lubrication?
48. Explain wedge film and squeeze film journal bearing. What is natural frequency and what is the relation b/w frequency and time?
49. What is meant by whirling of shafts?
50. What is Factor of safety?
51. What is plasticity and elasticity?
52. What are strain gauge rosettes?
53. What is a governor and what is the relation b/w speed and load in it?
54. What is poisson's ratio?
55. What is Gyroscope and state its equation?
56. What is the material used in the photo elasticity experiment?
57. Why balancing of masses is necessary?
58. What is a bearing and list the types?
59. Define sensitiveness, isochronous, governor effort?
60. What are the differences b/w flywheel and governor?
61. What is vibrometer and accelerometer?
62. What is the effect of aeroplane when propeller turns clockwise taking:  
a) left turn b) right turn

63. Define hook's law?
64. Write the pertroffs equation?
65. What is damping natural frequency?
66. Define Torsional vibration?
67. What is co-ordinate coupling?
68. What are the uses of critical damping?
69. Whether the earthquake is vibration or not?
70. How sound is produced in human lyrings?
71. Why simple pendulum swings in air when given an initial disturbance?
72. What is resonance?
73. What is indefinite system?
74. What is fringe constant?
75. Mention the different types of strain gauges?
76. What is Gauge Factor?
77. What is Forced vibration?
78. What are Journal Bearing, Hydrostatic bearing, Hydrodynamic bearing
79. What are Gas Bearings?
80. Define proof stress, offset stress?
81. What is Tangent Modulus?
82. What is plane stress, plane strain?
83. What is double shear & single shear in rivets?
84. Write the stress-strain curve for rubber, mild steel?
85. What is the difference b/w creep and slip in belt drives?
86. What is photo- elasticity?
87. What is friction and mention the different types in it?
88. List the laws of friction?
89. What is static and dynamic balancing?
90. What is endurance limit?
91. What is orthotropic material?
92. What is hoops stress?
93. What is ductility of a material?

  
Head of the Department,  
Mechanical Engineering Department  
R.Y.M. Engineering Collage,  
Cantonment, BELLARY-583 104